



pulsar
NS200



**THE WORLD'S
FAVOURITE
INDIAN**

Owner's Manual



FOREWORD



Welcome to the Pulsar family!

You are now the proud owner of the next generation **Pulsar NS200 BSVI**, India's No.1 sports bike. By No.1 we are talking about unparalleled performance, superior technology and incredible market leadership that Pulsar today enjoys. This makes the Pulsar you ride, unbeatable and unchallenged both on and off the road.

Before you ride out, please read this Owner's Manual carefully and familiarize yourself with the operating mechanism, controls and maintenance requirements of your Pulsar. This will ensure you a safe and trouble free ownership experience.

To keep your bike in perfect running condition and deliver consistent performance, we have specially programmed the periodic maintenance services which includes 3 Free and subsequent Paid services, as per the schedule contained in this booklet. We earnestly advise you to avail all these services at any of our Bajaj Dealers or Authorised Service Dealers (ASD), who are well equipped with all necessary facilities / genuine parts / oil and trained manpower to ensure the best care for your Pulsar. Your **Pulsar NS200 BSVI** comes with a warranty of **5 Years or 75,000 Kms** whichever occurs earlier from the date of sale. For details please refer to "Warranty : Scope & Limits" given in this manual.

Should you require any additional information feel free to contact us on helpline numbers or e-mail us at: **customerservice@bajajauto.co.in** or visit the Bajaj Auto website www.bajajauto.com

To be a part of the Pulsarmania, visit www.mypulsar.com and join the Pulsar fanpage on facebook: www.facebook.com/mypulsar

Rev up, shift gears and enjoy the Pulsar experience...

SERVICE DEPARTMENT
BAJAJ AUTO LIMITED

TABLE OF CONTENTS



Description			
1. Technical Specifications	1	25. Delivery Certificate	45
2. Identification Data	4	26. Warranty Scope & Limit	46
3. Location of Parts	5	27. Battery Warranty Card	49
4. Steering cum Ignition lock	6		
5. Fuel Tank Cap	7		
6. Speedometer Details	8		
7. Speedometer Setting	14		
8. Control Switches	16		
9. Pillion Seat / Tool kit	18		
10. Rider Seat / Battery	19		
11. Fitment of Rider & Pillion Seat	20		
12. Daily Safety Checks	21		
13. How to ride your Bike	22		
14. Safe Riding Tips	26		
15. Engine Oil	27		
16. Tube less Tyre & Tyre Pressure	28		
17. Battery	29		
18. Engine Cooling System	30		
19. Coolant	31		
20. Periodic Maintenance Information	32		
21. Brake Fluid	34		
22. Free Service Guidelines	35		
23. Periodic Maintenance & Lubrication Chart	36		
24. Non Use Maintenance	46		

Safety and Warning information :

Warning :



This indicates that a potential hazard or injury to you or other persons & to the vehicle can happen if advice provided is not followed.

Caution :



This indicates that a potential hazard that could result in vehicle damage. Follow the Advice provided with the caution.

Notice:

The description and illustration in this booklet are not to be taken as binding on the manufacturers. The essential features of the type described and illustrated herein remaining unaltered. Bajaj Auto Limited reserves the right to carry out at any moment without being obliged to bring this booklet upto-date & to do modifications on the vehicle, parts or accessories as may be convenient and necessary.

TECHNICAL SPECIFICATIONS



Parameter	Pulsar NS 200 BS VI
Engine	4 Stroke, Single Cylinder
Bore x Stroke	72 mm x 49 mm
Engine Displacement	199.4 cc
Compression Ratio	11 ± 0.5 : 1
Idling Speed	1500 ± 100 RPM
Max. Net Power	24.5 PS at 9750 RPM
Max. Net Torque	18.74 Nm at 8000 RPM
Ignition System	DC
Fuel System	Fuel injection System
Spark Plug	3 Nos.
Spark Plug Gap	0.8 ~ 0.9 mm
Lubrication	Wet sump forced Lubrication
Transmission	6 speed constant mesh
Gear shifting Pattern	1 Down 5 Up
Engine Cooling	Liquid cooled
Starting Aid	Electric starter
Front & Rear Brake	Disc Brake

TECHNICAL SPECIFICATIONS



Parameter	Pulsar NS 200 BS VI
Fuel Tank Capacity	
Full	12 Liters (No Reserve)
Dimensions	
Length	2017 mm
Width	804 mm
Height	1075 mm
Wheel base	1363 mm
Ground Clearance	168 mm
Front Tyre Size	100/80-17,52P Tubeless
Rear Tyre Size	130/70-17,62P Tubeless
Tyre Pressure	
Front	1.75 Kgf/cm ² (25 PSI)
Rear (Solo)	2 Kgf/cm ² (28 PSI)
Rear (with pillion)	2.25 Kgf/cm ² (32 PSI)
Electrical System	12 Volts DC
Battery	12V 8Ah VRLA
Head Lamp	Bulb-55/60 W
Tail / Stop Lamp	LED
Turn Signal Indicator	LED

TECHNICAL SPECIFICATIONS



Parameter	Pulsar NS 200 BS VI	
Position Lamp	Bulb-12V,5W-2 Nos.	
Side Indicator	Bulb 10W-4 Nos.	
Rear No. Plate Lamp	Bulb 12V,3W	
Speedometer	Neutral Indicator	LED-Green
	Hi-Beam Indicator	LED-Blue.
	Speedometer Illumination	LCD-Blue
	Fuel Level Indicator	LCD Bars
	Malfunction Indicator	LED-Yellow
	Coolant Temp. Indicator	LED-Red
	Low Oil Pr. Indicator	LED- Red
	Low Battery Indicator	LED-Red
	Bajaj Logo	LED-Blue
	REV Indicator	LED-Yellow
	Service Reminder	LCD
	Side Stand Indicator	LCD
ABS Indicator	LED-Yellow	
Horn	12V DC	
Vehicle Kerb Weight	158 kg.	
Vehicle Gross Weight	308 kg.	

Note : • All dimensions are under UNLADEN condition. • Above information is subject to change without any notice.
 • This vehicle complies to BS VI standards. • AHO is government regulation.

IDENTIFICATION DATA



The Frame and Engine serial numbers are used to register the motorcycle. They are the unique alpha-numeric codes to

identify your particular vehicle from others of the same model and type.

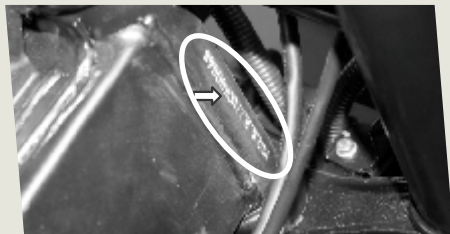

- ▶ **Frame Number Location**
On RH Side of Steering Tube
(Alpha-Numeric - 17 Digits)

Engine Number Location

On LH Side Crankcase Near Gear
Change Lever (Alpha-Numeric - 11 Digits)

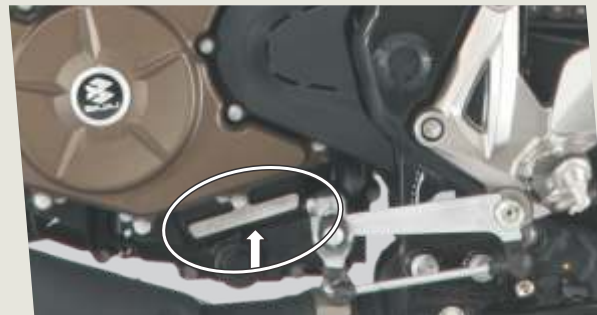

LOCATION OF PARTS - PULSAR RS200

pulsar
NS200



STEERING CUM IGNITION LOCK



Steering cum Ignition Lock :

It has three positions.



- **LOCK:** Steering locked. Ignition OFF.
- ⊗ **OFF:** Steering unlock. Ignition OFF.
- ⊗ **ON:** Steering unlock. Ignition ON.

To Lock the Steering : To lock the steering, turn the handle bar to the left side. Turn the handle bar to the left or right. Push & Rotate the key to "LOCK" position & remove the key.

Steering locking on handle position left hand side only.

To Unlock the Steering : Insert the key in steering cum ignition lock. Push & Rotate it clockwise to "OFF" or "ON" position.

Key : A common key is used for 'Steering cum Ignition lock', 'Fuel tank cap' & 'Rear Seat'.

"Cranking ON and OFF duration" control –

- During Engine crank cycle cranking is allowed only for fixed duration and in between successive cranks (in case engine does not start) here is a cooling off period.
- Cranking on-off duration control feature to avoid battery discharge-
 - 1st Crank ON (5 sec) & Disable for 2 sec.
 - 2nd Crank ON (5 sec) & Disable for 2 sec.
 - 3rd Crank ON (5 sec) & Disable for 10 sec.

After a gap of 10 sec cranking cycle continues.

- **Starter disabled if side stand down** – With side stand down condition and vehicle in gear, Engine cranking is disabled through ECU.
- Headlight control on rpm – Headlamp will be turned ON only at Engine running condition.

FUEL TANK CAP

pulsar
NS200



- There is no fuel cock.
- Always maintain minimum 3 Liter Petrol in fuel tank.
- Do not use adulterated fuel or fuel additives as it will result in rusting & clogging of Injector, Fuel pump module & catalytic Converter.

Fuel Tank Cap

- To open the fuel tank cap, open the flap. Insert the key in the lock and turn it clockwise and lift fuel tank cap.
- To lock the 'Fuel Tank Cap' insert the key in the lock and turn it clockwise and press fuel tank cap. 'Click' sound ensures cap is fully locked.

Precaution : Dont attach metallic 'Key chain' as it may damage paint of petrol tank cover.

⚠ Caution

- In case petrol is spilled out on petrol tank, it is to be immediately cleaned with clean soft cotton cloth to prevent permanent stain marks on petrol tank.

SPEEDOMETER DETAILS







pulsar
NS200



SPEEDOMETER DETAILS



Speedometer display will work when Ignition switch is in 'ON' position.

- Fuel Level Indicator:** It shows available fuel in fuel tank.
- Tachometer Dial:** It shows engine speed in RPM.
- Turn Signal Indicator LH/RH :** When Turn signal switch is pushed to Left or Right, Turn Signal Indicator - LH or RH will flash.
- Neutral Indicator:** When the transmission is in Neutral, Neutral indicator will glow.
- High Beam Indicator ():** It glows when Headlight is ON & Highbeam is selected with engine running.
- Low Oil Pressure Indicator ():** It glows when engine oil pressure is low.
- Malfunction Indicator ():** It glows whenever any abnormality is noticed in functioning of FI system related components.
- Coolant Temperature Indicator :** It glows when engine coolant temperature is more than 110°C.
- Low Battery Indicator:()** It indicates battery needs charging.
- Bajaj Logo:** Bajaj logo flying "B" continuously glow.
- Mode Button:** Mode button used for toggling between different modes e.g. ODO, Trip1, Trip2, DTE, service reminder and clock setting.
- Set Button:** Set button used for toggling between ODO to IFE, Trip1 to AFE1, Trip2 to AFE2, DTE to distance to next service and clock setting.
- Engine REV Indicator: ()** It glows when engine RPM is between 10,000 ~ 10,500 RPM. continuously ON at RPM more than 10,500.
- Gear Indication:** It will display gear position from 1 to 6. It will display "N" when vehicle is in neutral position.
- Side Stand Indicator:** It glows when side stand is down. starter will be disabled if side stand down - with side stand down condition & vehicle in gear, engine cranking is disabled through ECU
- Digital Clock:** It indicates time in HR: MM (AM/PM)
- Speedometer:** Vehicle speed will be displayed in digital form in Km/h
- Odometer:** The Odometer shows the total distance that the vehicle has covered. Odometer can not be reset to 'Zero'.
- Trip Meter:** Trip 1 & Trip 2 shows the distance traveled since it was last reset to zero.
- Service Reminder:** 'Wrench' symbol glows when ODO meter reading reaches to set Kms. It indicates vehicle is due for periodic service. This Icon will flash at -
1st: 450 km **2nd:** 4450 km, **3rd:** 9450 km
and subsequently at each 5000 kms. Icon will continue to glow till it is reset. This icon is to be reset after service is carried out.
- Low Fuel Level Indicator: ()** It blinks if fuel bar is \leq 1 bar.
- ABS Indicator ():** With Ignition switch ON the ABS indicator glows. When vehicle speed is more than 5 Km/h the ABS indicator goes off, if this indicator glows while vehicle is running, it means there is problem in ABS.

SPEEDOMETER DETAILS



Note :

After switching 'ON' the ignition switch, the following indications will remain 'ON' till engine is started.

- Coolant Temperature Indicator
- Low Battery Indicator
- Low Oil Pressure
- Malfunction Indicator

Instructions :

Incase, Coolant Temperature Indicator, Low Battery Indicator, Low Oil Pressure Indicator, Malfunction Indicator, ABS indicator gets ON during vehicle running, bring the vehicle to nearest BAL dealership for inspection / repair.

ABS System

- Dual Channel ABS System is fitted in Pulsar NS 200 BSVI vehicles .
- Dual channel ABS means ABS is fitted on front & rear wheels.

- Always maintain a safe distance between you and objects ahead. Vehicle speeds should always be reduced during extreme road conditions. The braking distance for motorcycle equipped with an anti-lock braking system may be longer than for those without it on rough road conditions. During these conditions the vehicle should be driven at reduced speeds
- When you apply Front brake / Rear brake by pressing Front brake lever / Rear brake pedal under conditions which may lock the wheels, you feel a corresponding sensation (pulsation) in Front brake lever/ Rear brake pedal. (as applicable to model) This is normal and it means ABS is active.
- ABS technology requires the rider to brake appropriately to ensure safer braking specially under acute conditions.
- Also it is recommended to use both front and rear brakes simultaneously.
- Always slow down when cornering. The anti-lock brake system cannot prevent accidents resulting from excessive speeds.
- Never drive by disconnecting wheel speedometer cable.

DETAILS - ODO & IFE

pulsar
NS200



Condition

Ignition switch is ON & Set push button not pressed, ODO will be displayed. In ODO mode, press Set push button, IFE will be displayed.

1. **ODO:** The Odometer shows the total distance that the vehicle has travelled.
2. **IFE (Instantaneous Fuel economy):** This will indicate fuel economy in km/L. at any given time. Value will be displayed only when vehicle speed & Engine RPM is more than zero.
If vehicle speed is zero then IFE will be displayed "--km/L"

Note:

IFE (Instantaneous fuel economy) / AFE (Average fuel economy) / DTE (Distance to empty) readings are indicative & may vary due to driving and road conditions.

DETAILS - AFE1,TRIP1 & AFE2, TRIP2

pulsar
NS200



Procedure to set AFE1 & TRIP1:

Ignition switch is ON & mode push button pressed for less than 1sec.- TRIP1 mode get selected.

Set push button pressed for less than 1 sec. in TRIP1 mode - AFE1 gets displayed.

1. **TRIP1:** The Trip meter shows the total distance that the vehicle has travelled in TRIP1 mode. If TRIP1 is reset, average fuel economy (AFE1) will reset.
2. **AFE1 (Average Fuel economy1):** This will indicate the average fuel economy in km/L in TRIP1 mode.

Procedure to set AFE2 & TRIP2:

Ignition switch is ON & mode push button pressed for less than 1sec.- TRIP2 mode get selected.

Set push button pressed for less than 1 sec. in TRIP2 mode - AFE2 gets displayed.

3. **TRIP2:** The Trip meter shows the total distance that the vehicle has travelled in TRIP2 mode. If TRIP2 is reset, average fuel economy (AFE2) will reset.
4. **AFE2 (Average Fuel economy2):** This will indicate the average fuel economy in km/L. in TRIP2 mode.

Note: AFE will be updated every 60 sec. AFE will be reset if corresponding TRIP1 or TRIP 2 is reset or battery disconnected.

DETAILS - DTE & TRIP



DTE (Distance to empty):

It indicates the estimated distance that the vehicle can travel under current fuel economy & fuel level condition.

DTE calculation is independent of TRIP and based on AFE for distance covered for last 25 Kms.

Max count of DTE is 990 Km. speedometer will display values in multiple of 10.



TRIP Setting:

If Set button is pressed more than 5 sec.in TRIP1 or TRIP 2 mode, then respective AFE & trip distance will reset to Zero while DTE will continue to show earlier value.

Note:

After completion of max value of 999.9 Km, selected trip display will get freezed and will not get set automatically to zero.

However speedometer will continue to calculate and display AFE value.

Note:

If vehicle is driven by ignoring fuel level display & Tank symbol () blinking after reaching fuel unutilized level DTE will be shown as '--' Km.

During Petrol Refilling:

If petrol filled is more than 1 Liter then DTE will be calculated based on the revised fuel volume.

If petrol filled less than 1 Liter then there will be no change in DTE value.

SPEEDOMETER SETTING

pulsar
NS200

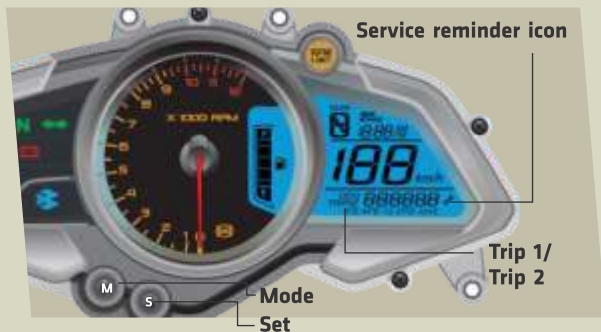

2. Service Reminder Reset (wrench icon) :

'Wrench' symbol glows when ODO meter reading reached to set Kms.

This icon will glow at-

1st : 450 Kms 2nd : 4450 Kms
3rd : 9450 Kms 4th : 14450 Kms
& subsequently at each 5000 Kms.

Note: Bring the motorcycle at authorised BAL dealership for re-setting the service reminder icon.

1. Trip Meter Reset :

• Mode & Set push button is provided for selecting & resetting 'ODO/ TRIP1/ TRIP2'.

- | | |
|------------------------------------------------|-------------------------------------------------------------------------------|
| 1. Press mode push button for less than 1 sec. | Mode changes from 'ODO/TRIP1/TRIP2' |
| 2. Press set push button for more than 5 sec. | Selected 'TRIP1/TRIP2' will reset.
Other TRIP mode will continue updating. |

SPEEDOMETER SETTING

pulsar
NS200

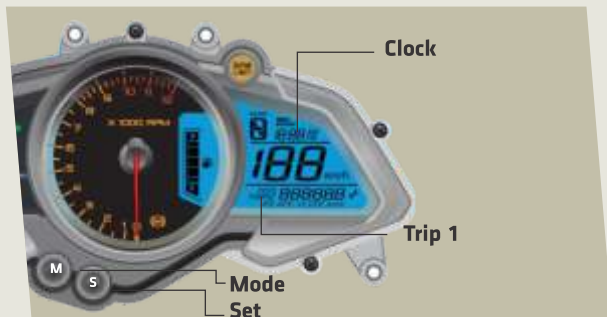

3. Clock Reset :

- Digital clock indicates time in HR & MM separated by colon ':'
- It is 12 hour clock.
- Initially ':' will be blinking
- Clock setting is possible in TRIP 1 mode only.

1. Press mode push button for less than 2 sec.	TRIP 1 Mode selected
2. Press mode & set push button together for more than 2 sec.	':' stops blinking Digits starts blinking
3. Press mode button for less than 1 sec.	Hour digits will increase.
4. Press set button for less than 1 sec.	Minutes digits will increase.
5. Press mode & set button together for more than 2 sec.	Set value will be saved Exit clock setting mode Digits stop blinking ':' start blinking
6. Clock set mode is selected & no editing is carried out for more than 5 sec.	Auto exit without saving set value. If engine/vehicle rpm is given then system will exit from clock set mode without saving set value.

CONTROL SWITCH - LH

pulsar
NS200

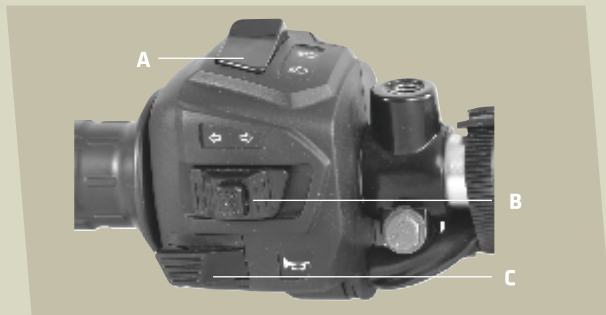

A. Hi / Lo Beam Switch:

Head Lamp high beam/low beam can be selected.

B. Turn Signal Switch: When the turn signal knob is pushed to Left (←) or Right (→) respective indicator will start blinking.

To stop blinking push the knob in & release.

C. Horn Button: (🔊) Press button for sounding horn.

D. Pass Switch: Press the switch to put on Hi Beam. It is used to give signal to vehicles coming from opposite side while overtaking.



CONTROL SWITCH - RH



E. Starter Button:

Starter button operates the electric starter. It is recommended to start the engine with the transmission in neutral.

Vehicle in Gear - Press clutch lever & operate starter button to start the engine.

F. Engine Kill Switch:

The engine kill switch is used for switching ON & OFF the engine.

☒ : Engine OFF

☑ : Engine ON

AHO (Automatic Headlight 'ON')

There is no 'Light switch' on RH control switch.

Ignition switch 'ON' Engine 'OFF'	Speedometer illumination Tail lamp, Number Plate Lamp, Pilot Lamp & Control Switches Illumination will get 'ON'
Effect of pressing 'Pass Switch'	In addition to above Hi-beam will get 'ON'

Ignition switch 'ON' & Engine Running

Speedometer illumination, Tail lamp, Number Plate Lamp, Pilot Lamp & Control Switches Illumination will get 'ON' in addition to above, head lamp will get on as given below.

Hi/Low beam Switch	Head Lamp Beam Status	Effect of Pass Switch
Low beam 'ON' ☒	Low beam 'ON'	Hi beam 'ON'
Hi beam 'ON' ☑	Hi beam 'ON'	No change

PILLION SEAT / TOOL KIT

pulsar
NS200

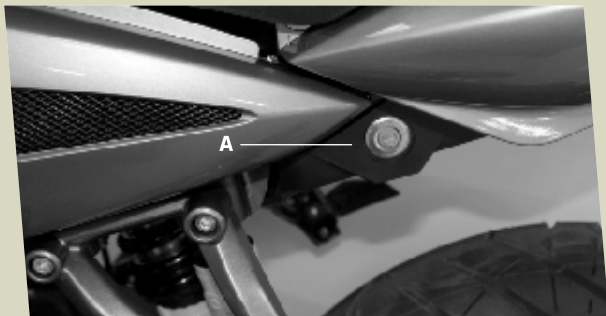

Removal of Pillion Seat

- Insert Key into lock (A)
- Turn the key clock wise.
- Lift front end of 'Rear seat'
- Pull 'Pillion seat' toward front side.
- Take out 'Pillion seat'.

Tool Kit Location

- It is located on RH side of Seat Cowl below the 'Pillion seat'.

First Aid Kit Location

- It is located on LH side of Seat Cowl below the 'Pillion seat'.

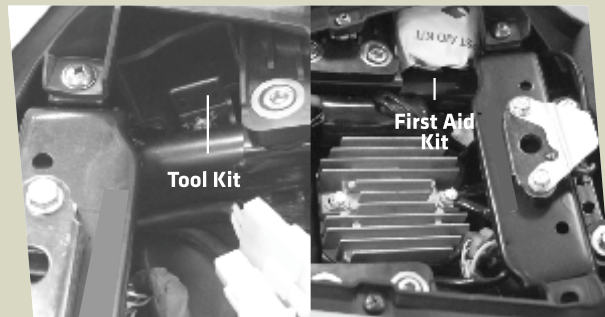

RIDER SEAT / BATTERY

pulsar
NS200

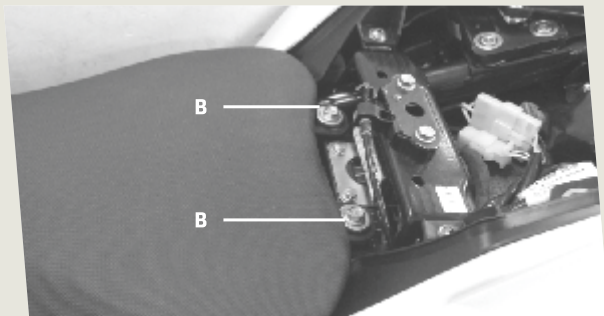

Removal of Rider Seat

- First remove 'Pillion seat'.
- Remove 'Rider seat' mounting bolts (B).
- Pull backward rear end of 'Rider seat'.
- Take out 'Rider seat'.

Battery

- It is located below 'Rider seat'.

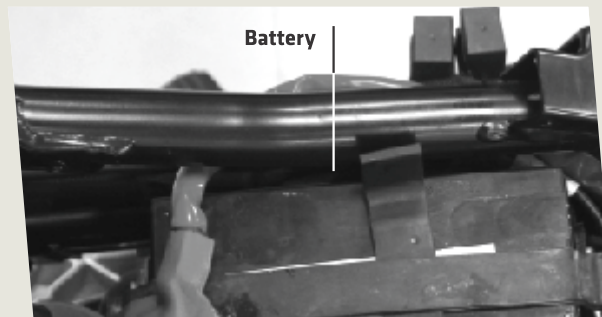

FITMENT OF RIDER & PILLION SEAT

pulsar
NS200

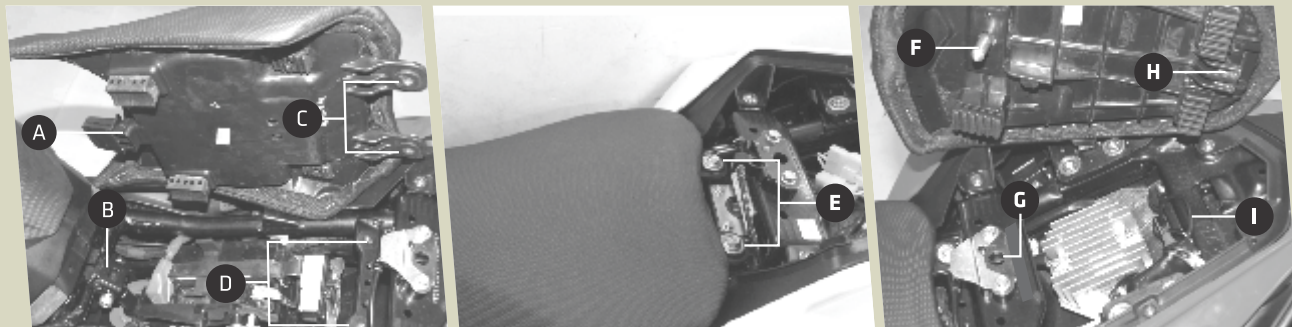

Fitment of 'Rider Seat'

- Match the bracket of 'Rider seat' (A) with slot (B).
- Push 'Rider seat' toward petrol tank.
- Match 'Rider seat' rear brackets (C) with the holes (D) provided on chassis.
- Tighten the bolts (E).

Fitment of 'Pillion Seat'

- First make sure 'Rider seat' is fitted properly.
- Ensure 'Tool kit' is located properly.
- Place 'Pillion seat' on fitment location.
- Match the bracket of 'Pillion seat' (H) with Hook (I).
- Insert lock rod (F) of seat into hook (G).
- Press front portion of seat.

DAILY SAFETY CHECKS

pulsar
NS200

Before riding motorcycle be sure to check following items. Please give proper importance to these checks and perform all of them before riding motorcycle.

If any irregularities are found during these checks, refer to the Maintenance chapter & see your dealer for the action required to return the motorcycle to a safe operating condition.

⚠ **Warning:** Failure to perform these checks every day before you ride may result in serious damage or severe accident.

- Enough **fuel level** for planned distance of journey. No fuel leakage in fuel lines.
- **Engine oil** level (between upper and lower level mark)
- **Throttle cable** play of 2 ~ 3 mm. Smooth operation and positive return to closed position,
- **Brake Fluid** level above MIN mark provided on reservoir, applicable to disc brake vehicle.
- **Drive Chain** slack of 15~25mm adequately lubricated.
- Function of all **lights & horn**
- **Clutch lever** play - 2 to 3 mm
- Check **Coolant level** between MIN and MAX mark in coolant reservoir tank.
- Smooth **steering movement** without restriction.
- **Side stand** return to It's fully up position.
- **Center stand** return to it's fully up position.
- Correct **inflation pressure** in both tyres. Adequate tyre tread depth - no cracks / cuts.
- Correct **rear viewing** span adjustment of mirror.
- Cleaning cloth not to be kept in vicinity of high temperature zone e.g. Radiator, engine, silencer assy, starter motor etc.
- Cleaning cloth to be strapped along with tool kit under rear seat assy.

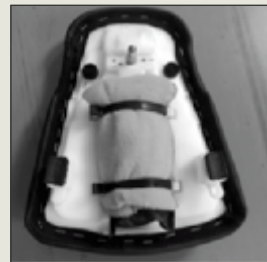

HOW TO RIDE YOUR BIKE



1. Starting The Engine:

- Ensure minimum 3 liters petrol is available in fuel tank.
- Turn ignition switch key to '⊗' position.
- Put kill switch in 'O' position.
- Confirm that transmission is in neutral / press the clutch lever if transmission is in gear.
- Keep throttle closed & press starter button,
- Release starter button as soon as engine starts.

"Cranking ON and OFF duration" control –

Cranking ON-OFF duration control feature to avoid battery discharge-

- 1st Crank ON (5 sec) & Disable for 2 sec.
- 2nd Crank ON (5 sec) & Disable for 2 sec.
- 3rd Crank ON (5 sec) & Disable for 10 sec. After a gap of 10 sec cranking cycle continues.

Note:

- The motorcycle is equipped with a Clutch switch. This switch facilitates engine starting in neutral and gear position.

Gear Position	Clutch lever position
Neutral	Released
Gear	Fully pressed

- In case of battery discharged condition please bring the vehicle to BAL authorised workshop for repairs.

2. Shifting Gears:

- Close throttle & press the clutch lever fully.
- Shift into next higher or lower gear.
- Open the throttle and release the clutch lever slowly and simultaneously.



Gear shifting Lever

Gear shifting pattern

3. Moving Off:

- Check that side stand is up.
- Press the clutch lever.
- Shift into 1st gear.
- Open the throttle and release the clutch lever slowly and simultaneously.
- As the clutch starts to engage, open the throttle a little more, giving the engine just enough rpm to keep it from stalling.

Recommended Speed for Shifting Down

From 6th to 5th Gear	54 km/h
From 5th to 4th Gear	45 km/h
From 4th to 3rd Gear	35 km/h
From 3rd to 2nd Gear	25 km/h
From 2nd to 1st Gear	15 km/h

▲ **Warning:** When shifting down to lower gear, do not shift at such high speed that engine rpm jumps excessively. This may cause engine damage, & rear wheel may skid. Downshifting should be done at recommended speeds as shown in table above.

4. Braking:

- Close the throttle completely, leaving the clutch engaged (except where shifting gears) so that the engine braking will help slow down the motorcycle.
- Shift down one gear at a time so that you are in Neutral when you come to a complete stop.
- When stopping, always apply both brakes at the same time.

5. Stopping the Vehicle :

- Close the throttle completely.
- Shift the transmission into neutral.
- Bring the vehicle to complete stop.
- Turn the ignition switch off.

6. Parking Using Side Stand:

- Support the motorcycle on a firm level surface with the side stand.
 - Lock the steering on LHS.
- ▲ **Caution:** Do not park on a soft or steeply inclined surface or the motorcycle may fall over.

HOW TO RIDE YOUR BIKE



7. Running IN

Proper running-in is important for the better life & trouble free performance of the vehicle.

- During first 2000 kms running-in period do not exceed following speed limits.

Kms	1st	2nd	3rd	4th	5th	6th
0 - 1000	10	20	30	40	50	60
1000 - 2000	20	30	40	50	60	70

- Always keep speed below the limits given in table.
- Do not REV the engine excessively.
- Do not start moving or REV the engine immediately after starting. Run the engine for a minute at idle speed to give the oil a chance to work up into the engine.

CAUTION

Always ensure side stand is UP while starting off.

Starter will be disabled if side stand down – With side stand down condition and vehicle in gear, Engine cranking is disabled through ECU & 'side stand down' Indication will be displayed in speedometer.

- Do Not REV engine in standstill condition.

If engine coolant temperature crosses 110°C, 'Coolant Temperature high' alarm message will be

- displayed on primary speedometer indicating engine is overheated. **If vehicle is further driven in such a condition coolant temperature will increase up to 115°C & ECU will not allow engine to run above 4500 RPM.**

- Always maintain engine oil / coolant level between MIN & MAX mark at vehicle upright position on level surface.

HOW TO RIDE YOUR BIKE



Ensure following maintenance points to get optimum performance from your bike.

Fuel	Always maintain minimum 3 Liter Petrol in fuel tank.
Spark Plugs	Inspect and clean spark plugs. Adjust electrode gap. Replace spark plugs as per P.M. Chart.
Air Filter	Replace as per Periodic Maintenance Chart.
Engine Oil	Check engine oil level. Always use recommended grade and quantity.
Brakes	Ensure that the brakes are not dragging / binding.
Clutch	Ensure correct clutch lever play.
Tyre Air Pressure	Always maintain recommended tyre pressure.
Brake Fluid	Always maintain brake fluid level above minimum mark. Ensure no leakage of brake fluid in brake system.
coolant	Always maintain coolant level between minimum & maximum mark. Ensure no leakage of coolant in cooling system.

Fuel Saving Tips :

A well maintained vehicle and good driving can contribute a lot to the saving of petrol. Following are a few simple fuel saving tips.

- Ride smoothly and steadily at an optimum driving speed to get best mileage.
- Avoid harsh braking.
- Change the gear judiciously according to the speed and load requirement.
- Don't overload the vehicle above the specified payload.
- Use the accelerator judiciously.
- Cut off the engine if you want to stop for more than two minutes.

How to check mileage (Fuel efficiency)

Best way to calculate mileage is by following the full tank to full tank method.

- Fill way tank full up to small mouth (brim).
- Run the bike for say 100 km.
- Fill the tank full again in same fuel filling station, probably with same fuel dispenser.
- Divide kilometer run / fuel quantity filled.

SAFE RIDING TIPS



- Always wear Helmet while driving or riding. Your helmet should conform to Indian standards.
- Read thoroughly the instructions given in this manual and follow them carefully.
- Avoid unnecessary accessories for the safety of both rider and other motorists.
- Get familiar and follow traffic rules & regulations in your states as well as general traffic signs.
- Familiarise yourself well with starting, acceleration and braking of the vehicle.
- When applying the brakes, use both front & rear brakes simultaneously. Applying only one brake may cause the vehicle to lose control.
- Riding at proper speed, avoiding unnecessary acceleration and braking are important for safety, low fuel consumption and longer life of the vehicle.
- During monsoon, drive vehicle more cautiously. Remember vehicle skid more easily during light showers.
- Keep both hands firmly on handle bar & both feet securely on rider footrest. Do not take away both hands & / or feet from resting area as this is very unsafe.

- Do not use mobile phones while riding as it could lead to fatal accident.
- It is suggested to customer to take appropriate care in area of heavy monsoon or high rainfall area. The appropriate surface preventive coat to avoid rusting / poor surface finish on account of adverse atmospheric conditions.
- Always carry vehicle registration & insurance papers, and a valid driving licence with you.

General Maintenance Tips :

- Vehicle cleaning to be done with soft & clean wet cloth to avoid scratches on painted parts.
- Clean & lubricate all the important parts as detailed in a periodic maintenance chart.
- Do not apply direct water jet on painted, electrical / electronic parts.
- Do not obstruct engine cooling by adding mud protection sheet from front
- Drive cautiously. Start early & reach your destination safely.
- Avoid driving on loose sand or stones where vehicle is likely to skid.
- Properly wrap-up loose clothes while driving or riding to avoid entangling in wheel or other objects on road.
- Always concentrate on riding for safety.

ENGINE OIL

pulsar
NS200

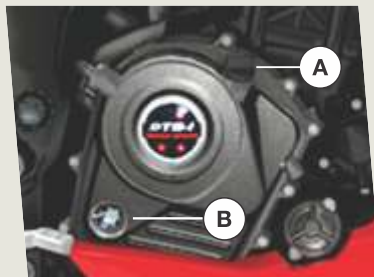

A : Oil Filler Cap
B : Oil Level Gauge

Engine Oil Level Checking:

- Check engine oil level every day. Park vehicle perpendicular to the ground on level surface.
- Check oil level through oil level gauge 'B'.
- Always maintain engine oil level between upper and lower mark provided on Cover RH. Top up with specified grade of oil if the oil level is below lower level mark.

Engine Oil Capacity:

- Refill at servicing : 1200 ml.
- During engine overhaul : 1400 ml.

Recommended Engine Oil:

Always insist on Bajaj DTS-i Engine Oil for optimum engine performance and warranty benefits. It is a specially formulated oil for vehicles with DTS-i engines.

Model	Recommended Engine oil
Pulsar NS200	Bajaj DTS-i 20W50 BS6 Compliant SAE 20W50 JASO 'MA2' API SN QR Bajaj DTS-i 10W50 Synthetic BS6 Compliant

- Engine oil replacement frequency : 1st service & then every 10,000 Km.
- Engine oil level top-up frequency : Every 5000 km.
- For all BS VI Vehicles, above BS VI compliant engine oil is to be used only. Use of BS 6 engine oil will give prolonged life of catalytic convertor.

⚠ Caution:

- It is most important to adhere to recommended grade & frequency of oil change for the purpose of long life of critical engine components. For details refer periodic maintenance chart.
- Do not reuse drained oil.

TUBELESS TYRE & TYRE PRESSURE



Tubeless Tyre :

The main advantage of tubeless tyres is in case of puncture the rate of air leak is very slow, hence customer can easily drive the vehicle upto nearest puncture repair shop for removing puncture.



Note:

Incase the motorcycle is fitted with imported tyres. compliance to respective Indian standard & central motor vehicle rules has been ensured.

Wheel Puncture:

- Visit nearest known tubeless tyre repair shop to remove puncture.
- Remove puncture by Filler or Plug method only.
- Do not use patch method to remove puncture of tubeless tyre.

△ Caution: Tubeless tyres are fitted in this motorcycle. The walls of the tyres in contact with the wheel rim should not be damaged in any way during fitment / removal of tyre. The tyre side walls in contact with wheel rim seals air.

Tyre Pressure:

Keep appropriate tyre pressure as mentioned below to increase life of the tyre & for better fuel consumption.

Model	Front Tyre	Rear Tyre
Pulsar NS200	25 PSI	28 PSI (Solo) 32 PSI With Pillion

- Tyre warranty is settled by tyre manufacturer.
- Decision is taken based on tyre wear and running of vehicle.
- BAL settles tyre warranty for only imported tyres.

BATTERY



Battery : 12V - 8 Ah VRLA

- Battery is located below Rider seat.

Battery Features :

- No topping-up is required
- Reduced self discharge, Enhance safety.
- No vent tube open to atmosphere hence no discharge of electrolyte through vent tube.

⚠ Caution:

Do not drive / run vehicle in battery disconnected condition. It may lead to damage of electrical / electronic components.

- Environment care must be taken to dispose off the used battery.
- It is always recommended to hand over the same to the Authorised battery / BAL dealer for proper disposal of the same.
- When 'Low battery icon' pop-up in speedometer display, it is advised to reach BAL dealer & get it charged immediately.
- Warranty on battery is 18 months from the date of purchase of vehicle.

How to keep battery healthy ?

- Switch 'Off' ignition when engine is not running.
- Get battery checked/ charged during periodic services.
- Do not add extra electrical accessories such as - Remote, Bigger Horn, Musical brake light etc. This will reduce life of battery & may damage ECU.
- Disconnect battery +ve & -ve wires if vehicle is to be stored for more than 2 weeks. This avoids self discharge.

ENGINE COOLING SYSTEM

pulsar
NS200

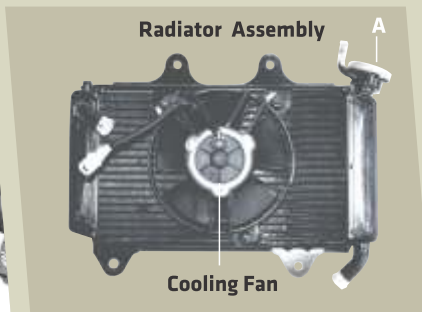
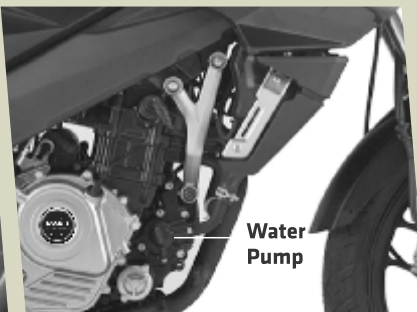
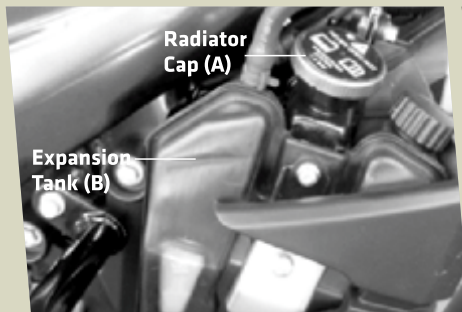

- Coolant is provided for cooling of engine.
- Water pump in the engine circulates the coolant in cooling system.
- The pressure resulting from the warming of the cooling system is regulated by a valve in radiator cap (A).
- Heat expansion causes excess coolant to flow into expansion tank (B).
- When the coolant temperature drops, this surplus coolant is sucked back into the cooling system.
- Cooling fan is provided for cooling of coolant circulated through radiator fins.

Note:

Fan will start at temp 95°C and stops at 90°C. This is normal condition & it indicates cooling system functioning well.

⚠ Warning:

During operation, the coolant gets very hot & is under pressure. In case of scalding, rinse immediately with lukewarm water. Do not remove radiator cap, radiator hose or other cooling system components when the engine is hot. Allow the engine & cooling system to cool down.

COOLANT



⚠ Warning:

Coolant is poisonous and causes health hazard.

Avoid contact between coolant & skin, eyes and clothing. If it gets into your eyes, rinse immediately with water and contact a doctor.

Wash affected skin areas immediately with soap and water. If coolant is swallowed, contact a doctor immediately. Change clothes that have come in contact with coolant. Keep coolant out of the reach of children.

Coolant Specifications :

Use antifreeze ready to use “Bajaj Koolex” coolant only.

Total coolant quantity:

1000 ml.

(750~780 ml in radiator &

220~230 ml expansion tank).

pulsar
NS200



Coolant Top up

- Park vehicle perpendicular to the ground on level surface by using side stand.
- Check coolant level in engine cold condition only.
- Ensure coolant level is between Min & Max mark.
- Always top up coolant through expansion tank cap (A).
- Always replace coolant with “Bajaj Koolex” coolant only.
- Use nitrile rubber hand gloves while draining & topping up coolant.
- Do not top up coolant through radiator cap.

PERIODIC MAINTENANCE INFORMATION

pulsar
NS200

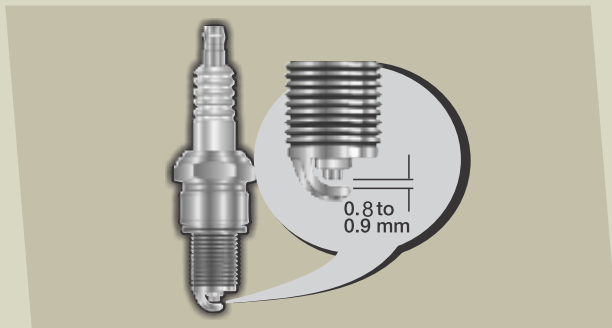

Spark Plug

- Remove spark plugs by using plug spanner.
- Clean the spark plugs.
- Adjust the gaps if incorrect by bending outer electrode carefully.

Spark Plug Gap: 0.8 to 0.9 mm.

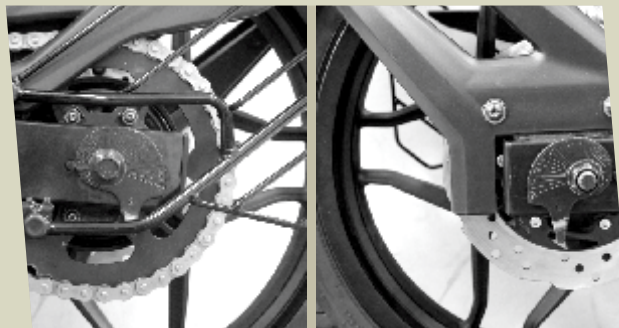

Drive Chain Slackness

- Chain slackness will have to be adjusted whenever required.
- Std. Chain slackness 15 ~ 25 mm.
- Marking on chain adjusters should be identically positioned on both sides.

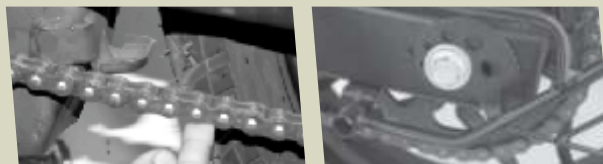

PERIODIC MAINTENANCE INFORMATION

pulsar
NS200

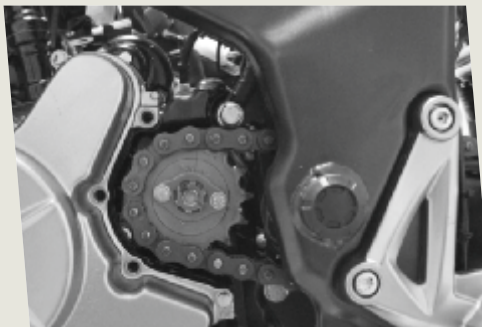

**Drive Chain
Cleaning**

Drive chain must be cleaned & lubricated as per periodic maintenance schedule.

Drive Chain (Sealed type)

- 'O' rings must always be kept wet for best performance hence lubricate every 500 Km.
- Sealed chain lubrication can easily be done by owners using Bajaj 'Chain Lube Spray Can' available with BAL dealers.



**Drive Chain
Lubrication**

Method of sealed type Chain Lubrication :

- Park vehicle perpendicular to the ground on level surface. Clean the chain by using lint free cloth (If excessive mud / slush found approach Bajaj Service Center for proper cleaning)
- Shake the can vigorously by holding vertically upright till the noise of steel ball inside heard uniformly.
- Hold spray can at the back of rear sprocket with extension tube nose at 5~10 cm.
- Rotate the wheel in reverse direction & spray the lube on middle portion of the chain up to full length of the chain.

BRAKE FLUID

pulsar
NS200



**Front Brake
Fluid
Reservoir**



**Rear Brake
Fluid
Reservoir**

Front & Rear Brake Fluid Level

- Front brake fluid reservoir is located on RH side of Handle bar.
- Rear brake fluid reservoir is located behind RH pillion holder bracket.
- To check the brake fluid level, Park the vehicle perpendicular to the ground on level surface with handle bar in straight ahead condition.

- Always ensure that brake fluid level is above 'MIN' mark given on inspection Window.
- In case of level drop, use only DOT-4 brake fluid (from sealed container) for top up & replacement.

FREE SERVICE GUIDELINES



Instruction to avail Free Service through Digitized Free Service Coupon

Please follow following procedure : -

- Please provide your mobile number to Dealer at the time of buying of new Bajaj Vehicle.
- In case of change in mobile number, please update to Dealer / ASD.
- When you are at Dealership / ASD workshop for availing Free Service, you will receive the 'Unique Coupon Number' (UCN) through SMS in your mobile.
- Please inform the UCN to Dealer / ASD at the time of Free Service.
(ASD-Authorised Service Dealer)

Periodic Service Criteria			
Service	Days	Kms	
1st Free Service	30~45	500~750	whichever occurs earlier
2nd Free Service	240	4500~5000	
3rd Free Service	360	9500~10000	
Subsequent Paid services	120 Days from last Service	Every 5000 Km after previous service	

Availing all Free / Paid Services, replacing mandatory periodic parts & engine oil will entitle warranty eligibility.

PERIODIC MAINTENANCE & LUBRICATION CHART



Sr. No.	Activities / Check points	Recommended frequency - Service interval & Kms							
		Servicing	1st (Free)	2nd (Free)	3rd (Free)	4th	5th	6th	7th
		KMS	500 750	4500 5000	9500 10000	14500 15000	19500 20000	24500 25000	29500 30000
1.	Servicing with water wash	✓	✓	✓	✓	✓	✓	✓	✓
2.	Engine oil (Bajaj DTSI 10000 oil)	Top-up,R	R	Top-up	R	Top-up	R	Top-up	R
3.	Engine oil Filter	R	R		R		R		R
4.	Oil strainer	CL	CL		CL		CL		CL
5.	Air cleaner element** & air filter cover 'O' ring. Drain tube cleaning.	R					R		
6.	in-line fuel filter	R				R			R
7.	Inline fuel filter nylon hoses with quick connector	C,R					C,R		
8.	Spark plug clean & check gap	CL,A, R			CL,A		CL,A		R
9.	Valve tappet clearance	C, A				C, A			C, A
10.	Throttle body rubber duct (Sleeve) for hard resulting in loose fitment.	C,R				C,R	C,R	C,R	C,R
11.	Engine breather tube for cracks.	C,R			C,R	C,R	C,R	C,R	C,R
12.	EVAP system Hoses- check for cracks	C,R		C,R	C,R	C,R	C,R	C,R	C,R
13.	Radiator fins	C,R		C,R	C,R	C,R	C,R	C,R	C,R

PERIODIC MAINTENANCE & LUBRICATION CHART



Recommended frequency - Service interval & Kms									Remarks
8th	9th	10th	11th	12th	13th	14th	15th	16th	
34500 35000	39500 40000	44500 45000	49500 50000	54500 55000	59500 60000	64500 65000	69500 70000	74500 75000	
✓	✓	✓	✓	✓	✓	✓	✓	✓	Ensure to prevent water entry in Petrol tank, Silencer & electrical parts. Use caustic free detergent for washing.
Top-up	R	Top-up	R	Top-up	R	Top-up	R	Top-up	Use BGO 20W50 BS6. Alternate BGO 10W50 BS6. Oil level window cleaning at every 10000 kms by petrol spray & nylon brush.
	R		R		R		R		Replace oil filter in 1st service & at every 10000 Kms
	CL		CL		CL		CL		Oil strainer cleaning at the time of oil change.
	R				R				Replace viscous filter at every 20,000 kms No Cleaning
		R			R			R	Replace at every 15000kms
	C,R				C,R				Replace if required
	CL,A		CL,A		R		CL,A		Replace at every 30000 kms
		C, A			C, A			C, A	
C,R	C,R	C,R	C,R	C,R	C,R	C,R	C,R	C,R	Replace if required
C,R	C,R	C,R	C,R	C,R	C,R	C,R	C,R	C,R	Replace if required
C,R	C,R	C,R	C,R	C,R	C,R	C,R	C,R	C,R	Drain EVAP "Y" connection drain tube. Replace if found cut / damaged
C,R	C,R	C,R	C,R	C,R	C,R	C,R	C,R	C,R	If found damaged, replace it

PERIODIC MAINTENANCE & LUBRICATION CHART



Sr. No.	Activities / Check points	Recommended frequency - Service interval & Kms							
		Servicing	1st (Free)	2nd (Free)	3rd (Free)	4th	5th	6th	7th
		KMS	500 750	4500 5000	9500 10000	14500 15000	19500 20000	24500 25000	29500 30000
14.	Check Coolant level in expansion tank / Hose clamp adjustment	C,A	C,A	C,A	C,A	C,A	C,A	C,A	C,A
15.	Coolant & Radiator hoses	Replacement at every 30000 Kms or 3 year (whichever occurs earlier)							
16.	Engine foundation silent bushes for cracks	C,R			C,R		C,R		C,R
17.	Silencer drain hole cleaning	CL			CL	CL	CL	CL	CL
18.	Water Pump seals	R							
19.	Wiring harness connections, routine & Conduit / PVC sleeve inspection.	C,A,T	C,A,T	C,A,T	C,A,T	C,A,T	C,A,T	C,A,T	C,A,T
20.	Battery , connections & health by load tester. +ve terminal cap fitment.	C,A,L,T	C,A,L,T	C,A,L,T	C,A,L,T	C,A,L,T	C,A,L,T	C,A,L,T	C,A,L,T
21.	Ignition switch contacts cleaning	CL,L			CL,L	CL,L	CL,L	CL,L	CL,L
22.	HT coil connections (Primary and Secondary)	C,T		C,T	C,T	C,T	C,T	C,T	C,T
23.	Starter motor & starter relay connections	C,T		C,T	C,T	C,T	C,T	C,T	C,T
24.	Oil pressure indicator check on console post ignition ON.	C,R	C,R	C,R	C,R	C,R	C,R	C,R	C,R
25.	Check fault code, Clear fault history, Update latest hex file if applicable	C	C	C	C	C	C	C	C
26.	sealed Drive chain wear** - Clean, Lubricate & adjust. Replace if required	CL,L,A	CL,L,A	CL,L,A	CL,L,A	CL,L,A	CL,L,A	CL,L,A	CL,L,A

PERIODIC MAINTENANCE & LUBRICATION CHART



Recommended frequency - Service interval & Kms									Remarks
8th	9th	10th	11th	12th	13th	14th	15th	16th	
34500 35000	39500 40000	44500 45000	49500 50000	54500 55000	59500 60000	64500 65000	69500 70000	74500 75000	
C,A	C,A	C,A	C,A	C,A	C,A	C,A	C,A	C,A	Coolant top up if required Use BAJAJ Koolex coolant only.
Replacement at every 30000 Kms or 3 year (whichever occurs earlier)									
	C,R		C,R		C,R		C,R		Replace if required
CL	CL	CL	CL	CL	CL	CL	CL	CL	
	R								
C,A,T	C,A,T	C,A,T	C,A,T	C,A,T	C,A,T	C,A,T	C,A,T	C,A,T	Damaged conduit / PVC sleeves protection by applying electrical tape film
C,A,L,T	C,A,L,T	C,A,L,T	C,A,L,T	C,A,L,T	C,A,L,T	C,A,L,T	C,A,L,T	C,A,L,T	Apply petroleum jelly on battery terminals. Use midtronics battery tester
CL,L	CL,L	CL,L	CL,L	CL,L	CL,L	CL,L	CL,L	CL,L	Use recommended WD40 spray
C,T	C,T	C,T	C,T	C,T	C,T	C,T	C,T	C,T	
C,T	C,T	C,T	C,T	C,T	C,T	C,T	C,T	C,T	
C,R	C,R	C,R	C,R	C,R	C,R	C,R	C,R	C,R	Icon should disappear post engine ON. After 4000 rpm, no icon should be displayed.
C	C	C	C	C	C	C	C	C	
CL,L,A	CL,L,A	CL,L,A	CL,L,A	CL,L,A	CL,L,A	CL,L,A	CL,L,A	CL,L,A	During 1st free service use OKS spray for chain cleaning without removing chain from vehicle. •During other services clean chain with Diesel+SAE 90 oil ratio of 50:50 & lubricate by SAE 90 oil.(Customer to use OKS chain lub spray at every 500 kms)

PERIODIC MAINTENANCE & LUBRICATION CHART



Sr. No.	Activities / Check points	Recommended frequency - Service interval & Kms							
		Servicing	1st (Free)	2nd (Free)	3rd (Free)	4th	5th	6th	7th
		KMS	500 750	4500 5000	9500 10000	14500 15000	19500 20000	24500 25000	29500 30000
27.	side stand pivot pin	C,L					C,L		
28.	Steering play	C,A	C,A	C,A	C,A	C,A	C,A	C,A	C,A
29.	Steering stem bearing & Cap steering bearing (Plastic)**	C,CL,L			C,CL,L		C,CL,L		C,CL,L
30.	Front fork oil & seal	C,R	C,R	C,R	C,R	C,R	C,R	C,R	R
31.	Step-pillion LH & RH (Ball & Plate)	CL,L		CL,L	CL,L	CL,L	CL,L	CL,L	CL,L
32.	Swing arm NRB for more play	L							
33.	Brake pads for wear limit.	C,R	C,R	C,R	C,R	R	C,R	C,R	R
34.	Check source of leakages if any in the brake system. Check Front & rear brake hose condition. Check Brake fluid level and top up, if needed.	C,A,R	C,A,R	C,A,R	C,A,R	C,A,R	C,A,R	C,A,R	R
35.	Rear sprocket fasteners for looseness.	C,T	C,T		C,T		C,T		C,T
36.	Rear wheel rubber shock dampers for excess play.	C,R			C,R		C,R		C,R
37.	Fairing & windshield well nuts for rubber cracks	C,R			C,R	C,R	C,R	C,R	C,R
38.	Clutch & Throttle cable free play adjustment	C,A	C,A	C,A	C,A	C,A	C,A	C,A	C,A
39.	Head light focus adjustment	C,A	C,A	C,A	C,A	C,A	C,A	C,A	C,A
40.	Check & confirm all bulbs / switches working.	C,A	C,A	C,A	C,A	C,A	C,A	C,A	C,A

PERIODIC MAINTENANCE & LUBRICATION CHART



Recommended frequency - Service interval & Kms									Remarks
8th	9th	10th	11th	12th	13th	14th	15th	16th	
34500 35000	39500 40000	44500 45000	49500 50000	54500 55000	59500 60000	64500 65000	69500 70000	74500 75000	
	C,L				C,L				Use recommended AP grease.
C,A	C,A	C,A	C,A	C,A	C,A	C,A	C,A	C,A	
	C,CL,L		C,CL,L		C,CL,L		C,CL,L		Replace if required. Use Limaplex grease for lubrication
C,R	C,R	C,R	C,R	C,R	R	C,R	C,R	C,R	Replace oil and oil seal and dust seal in pair at every 30000 Kms.
CL,L	CL,L	CL,L	CL,L	CL,L	CL,L	CL,L	CL,L	CL,L	Replace ball & plate, if required.
	L								Lubricate at every 40,000 Kms.
C,R	C,R	R	C,R	C,R	R	C,R	C,R	R	Replace at every 15000 Kms.
C,A,R	C,A,R	C,A,R	C,A,R	C,A,R	R	C,A,R	C,A,R	C,A,R	Check & Top up DOT 4 brake oil in every service. Replace DOT 4 brake oil & Master / Caliper seals at every 30000 Kms.
	C,T		C,T		C,T		C,T		Use model wise torque values.
	C,R		C,R		C,R		C,R		Replace rear wheel rubber shock damper if required
C,R	C,R	C,R	C,R	C,R	C,R	C,R	C,R	C,R	Replace if required.
C,A	C,A	C,A	C,A	C,A	C,A	C,A	C,A	C,A	Replace cables if operation found hard.
C,A	C,A	C,A	C,A	C,A	C,A	C,A	C,A	C,A	
C,A	C,A	C,A	C,A	C,A	C,A	C,A	C,A	C,A	Contact type switches if found sticky then use recommended WD40 spray

PERIODIC MAINTENANCE & LUBRICATION CHART



Sr. No.	Activities / Check points	Recommended frequency - Service interval & Kms							
		Servicing	1st (Free)	2nd (Free)	3rd (Free)	4th	5th	6th	7th
		KMS	500 750	4500 5000	9500 10000	14500 15000	19500 20000	24500 25000	29500 30000
41.	General lubrication – Clutch lever	L	L	L	L	L	L	L	L
42.	Tyre air pressure.	C,A	C,A	C,A	C,A	C,A	C,A	C,A	C,A
43.	Mirror position & joint firmness.	C,A	C,A	C,A	C,A	C,A	C,A	C,A	C,A
44.	All fasteners tightness, few are, Front & rear axle, Swing arm axle, Engine foundation, Rider foot rest, Pillion stay	C,T	C,T	C,T	C,T	C,T	C,T	C,T	C,T

****More frequent cleaning may be required while driving in dusty environment.**

C : Check, A : Adjust, CL : Clean, R : Replace, T : Tighten, L : Lubricate

Note : Periodic parts, Oil, Coolant, Filters, All types of greases, Cleaning agents, Cables, Wear & tear parts, Rubber 'O' rings / oil seals / pipes, Gaskets to be replaced as per Periodic Maintenance and Lubrication Chart are mandatory and the same are chargeable to customer.

PERIODIC MAINTENANCE & LUBRICATION CHART



Recommended frequency - Service interval & Kms									Remarks
8th	9th	10th	11th	12th	13th	14th	15th	16th	
34500 35000	39500 40000	44500 45000	49500 50000	54500 55000	59500 60000	64500 65000	69500 70000	74500 75000	
L	L	L	L	L	L	L	L	L	Use recommended AP grease.
C,A	C,A	C,A	C,A	C,A	C,A	C,A	C,A	C,A	Ensure model wise tyre air pressure.
C,A	C,A	C,A	C,A	C,A	C,A	C,A	C,A	C,A	
C,T	C,T	C,T	C,T	C,T	C,T	C,T	C,T	C,T	Use model wise torque values.

NON USE MAINTENANCE



Non-use maintenance is necessary if a vehicle remains off road for a longer duration (more than 15 days**). The correct and careful non-use maintenance carried out before storing the vehicle will prevent the vehicle from rusting and from such other non-operational damages like fire hazards.

- Clean the entire vehicle thoroughly.
- Empty the fuel from the fuel tank (if fuel is left in for a longer time, the fuel will break and gummy substance could clog the fuel system & fuel pipe).
- Remove spark plug & put several drops of engine oil into the cylinder. Kick engine over slowly a few times to coat cylinder wall with oil & install back spark plug.
- Set the vehicle on a box or a stand so that both wheels are raised off the ground.
- Spray oil on all unpainted metal surfaces to prevent rusting. Avoid getting oil on rubber parts or brake liners.
- Cover entire vehicle neatly. Make sure that storage area is well ventilated & free from any source of flames or spark.
- Fill 10% excess air pressure in both wheels.
- Do not apply oil on front brake disc, to prevent rusting. If the front brake disc rusts during storage, do not attempt to clean it with soap water. The rust will go off automatically during first few application of brake.

** For Battery :

- a. Remove battery and keep it on wooden plank, in properly ventilated area.
 - b. Before taking the vehicle for use.
- Get the battery recharged from the Authorised Service Dealer / Battery Dealer.
 - Apply petroleum jelly on battery terminals.

Preparation for regular use after storage :

- Follow daily safety checks.

DELIVERY CERTIFICATE



FRAME NO.: - -

ENGINE NO.: - -

Sold on.: _____

Customer's Name Mr/Mrs/Miss : _____

Address: _____ Contact No.: _____

I have taken possession of motorcycle along with the following items.

1. Owner's Manual

5. Standard Accessories

2. 2 nos of key

6. Battery

Make _____ Sr. No. _____

3. Set of tools

7. Tyre

Fr Make _____ Sr. No. _____

4. First Aid Kit

Rr Make _____ Sr. No. _____

The Vehicle has been delivered to my satisfaction & I have understood all terms and conditions of warranty, service schedules & maintenance tips and shall abide by them.

Dealer Code :

Dealer Name :

Address :

Contact No. :

Customer's Signature

(To be filled in by the dealer)

Important - Dealership should take customer sign & maintain the record of this (Delivery Certificate).

WARRANTY : SCOPE & LIMIT



Bajaj Auto Limited provides the following warranty in respect of the **"Pulsar NS 200 BS VI"** motorcycle manufactured by us.

Every possible care and precaution has been taken to ensure quality in respect of the material & workmanship in the vehicles manufactured by us. Bajaj Auto Limited will repair or replace at their Authorised Workshops, free of charge, part or parts there of as may be found, on examination, to have manufacturing defect within a period of 5 Years or 75,000 Kms., whichever is earlier from the date of sale subject to fulfillment of conditions stipulated in part A, B & C given here under

Note : Warranty is applicable for only first owner of vehicle.

Part A:

Warranty claims in respect of such items like shock absorbers, speedometers etc. though claimed through us, are subject to acceptance of the respective manufacturers. In all such cases the decision of the respective manufacturer will be final and binding.

Proprietary parts like tyres, tubes and battery are warranted by their respective manufacturers and should be claimed on them directly by the customer. Bajaj Auto Limited shall not be Liable to replace them though their dealer, however BAL Dealers will provide full assistance in

referring such claims with respective manufacturer.

Bajaj Auto Limited undertake no liability in the matter of consequential loss or damage caused due to the failure of the parts. Delay, if any, at the repairing workshop in carrying out repair to vehicle shall not be a ground for extending the warranty period, nor shall it give any right to the customer for claiming any compensation for damages.

Bajaj Auto Limited reserves the right either to repair or replace the defective parts.

Where a defective part can be replaced by part/s of alternative brand/s, which are normally used by Bajaj Auto Limited in the course of manufacture, Bajaj Auto Limited reserves the right to carry out the replacement by a part or parts of any such alternative brand/s.

This warranty and any claim arising there, is subject to Pune jurisdiction only.

Part B:

No claim for exchange or repair can be considered unless the customer :

- a. Ensures that immediately upon detection of the defect, he approaches any nearest BAL Authorised Vehicle Dealers & Recommended BAL Authorised Service Dealers with the concerned vehicle and enables him to remove and despatch the part / parts

WARRANTY : SCOPE & LIMIT



- attributing to the manufacturing defect to the Company.
- b. Produces the Owner's Manual, in original, to enable that dealer to verify the details.
- It must be expressly understood that claims forwarded directly to us by the owner / customer will not be entertained at all and such defective part/parts thus forwarded by them will lie at our factory at their own risk, and this warranty shall not be enforceable.

To avail benefits of warranty, following are mandatory

1. Availing of Initial 3 Free Services without lapse.
2. Availing paid services at subsequent 5000 kms. or 120 days from last service whichever is earlier without any lapse.
3. Availing of all services at the BAL Authorised Dealers & Recommended BAL Authorised Service Dealers.
4. Usage of only recommended engine oil "**Bajaj DTS-I 10000 10W50**" at specified frequency for drain interval of 10,000 kms. & engine oil level top-up at 5000 kms.
5. Replacing mandatory periodic parts such as air filter, oil filter etc. as per periodic maintenance schedule.

Part C :

Further this warranty is NOT applicable to :

1. Normal maintenance operations like brake & clutch adjustments, cleaning of fuel system, engine tune-up or such other adjustments.
2. Parts subjected to normal wear & tear like Clutch Plates, Brake Shoes, Chain, Sprockets, Fork Oil Seal, Spark Plug, Control Cables, Brake Pads.
3. Replacement of bulbs & rubber components like grommets, 'O' rings, bellows as well as filters, packings, gaskets, fasteners etc.
4. Painted parts. Only blistering or peeling off of paint film are covered under warranty. Any defect arising out due to external damages or due to usage of protective covers /additional protective coatings adverse atmospheric conditions etc. are not allowed like under warranty.
5. All consumables like Engine oil, Fork oil, Brake Oil, Grease etc. are chargeable to customer.
6. Any defect arising due to above consumables not changed as per scheduled or if used other than the recommended one.
7. Never drive your bike through flooded roads or a flooded patch, as damages to the engine parts due to water entry is not covered under warranty.

WARRANTY : SCOPE & LIMIT



8. All chrome plated parts are prone to rust or corrosion in coastal area or in acidic environment or due to neglected cleaning etc. However chrome film peeling is covered under warranty in general atmospheric conditions. Blue/ Yellow colouration of silencer near exhaust port is permissible and hence not covered under warranty.
 9. Oxidation of unpainted/painted crankcase, cylinder block, cylinder head etc. in acidic environment or in a coastal area.
 10. Parts of the vehicle that have been subjected to misuse, accident, negligent treatment OR which have been used in conjunction with parts & an equipment not manufactured or recommended for use by Bajaj Auto Limited, if found is the sole judgement of Bajaj Auto Limited, such use prematurely affects the performance and reliability of the vehicle.
 11. Parts of the vehicle that have been altered and modified or replaced in unauthorized manner like use of wider tyres, loud silencers etc and which in the sole judgement of the Bajaj Auto Limited affects its performance and reliability.
 12. **Vehicles which are not being serviced at recommended dealers as per the service schedule described or which have not been operated or maintained in accordance with the instructions maintained in the Owner's Manual.**
 13. Vehicles used for any competition or race and/or for attempting to set up any kind of record.
 14. Any failure arising due to use of adulterated or bad quality fuel.
Parts affected due to bad fuel quality are not covered Under warranty.
 15. If additional electrical accessories such as - Remote, Bigger horn, Musical brake light etc. fitted on vehicle.
 16. If the vehicle has been used for commercial purpose like Taxi or any other means of commercial transportation.
- Bajaj Auto Limited reserves the right to make any changes in design or to add any improvements on the vehicle at any time without incurring any obligation to install the same on a vehicle previously supplied and sold. Also, the conditions of this warranty are subject to alteration without any notice.
- This warranty is the entire written warranty given by Bajaj Auto Limited for "Pulsar NS 200 BS VI" motorcycle' and no other dealer or its or his agent or employee is authorised to extend or enlarge this warranty.

BATTERY WARRANTY CARD



MAKE OF BATTERY : MFG. CODE OF BATTERY :

BATTERY SR. NO.: BATTERY CHARGING DATE : _____

TYPE OF BATTERY : _____ VEHICLE SALE DATE : _____

NAME OF OWNER AND ADDRESS : _____

TYPE OF VEHICLE : _____ REG. NO.: _____

FRAME NO.: _____ ENGINE NO.: _____

SERVICE RECORD

Sr. No.	Date	Age Mths.	Voltage	Remarks	Dealer's Stamp & Signature	* Code
1						
2						
3						
4						
5						
6						

- * Code For Remarks:**
- AE:** Electrical system needs attention.
 - IR :** Insufficient running of vehicle.
 - CB :** Cover broken.
 - BC :** Broken Container.
 - PM :** Poor maintenance.
 - BA:** Battery abused.

Note : Customer should insist that "Service Record" must be filled by respective authorised battery dealer as proof of specified maintenance for easy settlement of claim, if any.

TO BE FILLED IN BY BATTERY DEALERS / DISTRIBUTORS IN CASE OF CLAIM



Name of Dealer & Code : _____

Date of claim : _____ Battery Type : _____

Serial No. : _____ Date of Fitment : _____

Failure Mode (Please tick as applicable)

- Loose connection
- Internal Short
- Plate Shedding
- Wrong Assembly
- Wrong Application
- Overcharge / Undercharge
- Reverse Charge
- Does not Hold Charge
- Left Lying Idle
- Terminal Corroded

Claim Accepted

Claim Rejected

Details of Repair, if any _____

Note:

Please contact nearest respective authorised battery dealer for details immediately after purchase of vehicle.

USE ONLY BAJAJ GENUINE PARTS

pulsar
NS200



THE WORLD'S
FAVOURITE
INDIAN

Always Use
Bajaj Genuine
High Performance
Engine Oils

4T
Premium
Engine Oil

*Synthetic oil for more engine life**

BAJAJ
DTS-i
10,000
20W 50



Top up
bottle



BAJAJ
DTS-i
10,000
10W 50
synthetic



Top up
bottle



Long Drain Interval of 10,000 kms*



Reduced Friction



Clean Engine Parts,
Longer Engine Life



Smooth Clutch
Control



*as per customer's choice

* Top up recommended at 5,000 kms

We are committed to provide the best of sales & service experience, however should you require any additional assistance, please call our Call centre on the number given below.



: 7219821111

Call charges are as applicable

**Call centre timings :- Monday to Sunday
(09 : 00 am - 08 : 00 pm)**



Please download customer care app from '**Google play store**' and '**Apple store**' and book the vehicles for servicing and more on your phone.

E-mail : customerservice@bajajauto.co.in

Web Site : www.bajajauto.com

CIN : L65993PN2007PLC130076