



*pulsar*  
N125



THE WORLD'S  
FAVOURITE  
INDIAN

## Owner's Manual



To keep your bike in perfect running condition, please follow the periodic maintenance services which includes **3 Free and subsequent Paid services**, as per the schedule contained in this booklet.

अपनी बाइक को सही चलती हालत में रखने के लिए, कृपया आवधिक रखरखाव सेवाओं का पालन करें जिसमें **3 नि:शुल्क और बाद में भुगतान सेवाएं शामिल हैं**, इस पुस्तिका में दिए गए अनुसूची के प्रति।

आपली बाईक परिपूर्ण स्थितीत चालू ठेवण्यासाठी कृपया या बुकलेटमध्ये दिलेल्या शेड्यूलनुसार पीरिऑडिक मेन्टेनन्स सर्विसेचे अनुकरण करा. **यात 3 फ्री आणि त्यानंतरच्या पेड सर्विसेस समाविष्ट आहेत.**

ನಿಮ್ಮ ಬೈಕ್ ಸಂಪೂರ್ಣ ಚಾಲನಾ ಸ್ಥಿತಿಯಲ್ಲಿರಿಸಲು, ದಯವಿಟ್ಟು ಈ ಕೈಪಿಡಿಯಲ್ಲಿ ನಮೂದಿಸಲಾದ ಶೆಡ್ಯೂಲ್ ನಂತೆ ನಿಯತಕಾಲಿಕ ನಿರ್ವಹಣಾ ಸೇವೆಗಳನ್ನು ಅನುಸರಿಸಿ. ಇವು 3 ಉಚಿತ ಮತ್ತು ನಂತರ ಪಾವತಿ ಸೇವೆಗಳನ್ನು ಒಳಗೊಂಡಿರುತ್ತವೆ.

உங்களுடைய பைக்கை மிக நன்றாக ஓடும் நிலையில் வைத்திருப்பதற்கு, இந்தக் கையேட்டில் கொடுக்கப்பட்ட அட்டவணையில் உள்ளவாறு 3, லவச மற்றும் தொடர்ச்சியான கட்டண சேவைகளை உள்ளடக்கிய காலமுறை பராமரிப்பு சேவைகளை தயவு செய்து பின்பற்றவும்.

میں بیکے چکڑی رنننگ کونڈیشن میں رکھنے کے لیے، برائے مہربانی وقت و وقت سے میینٹیننس کی خدمات پر عمل کریں جس میں شامل ہیں: اس کتابچے میں دئے گئے وقت کے مطابق 3 مفت سروسز اور بعد کی پیڈ سروسز۔

ಗ್ರಾಹಕರ ಬೈಕ್‌ನ ಸರಿಯಾದ ಚಲನೆಯನ್ನು ಕಾಯ್ದುಕೊಳ್ಳಲು, ಕೃಪೆಯಿಂದ ಈ ಪುಸ್ತಕದಲ್ಲಿರುವ ನಿರ್ದಿಷ್ಟವಾಗಿರುವ ಸೇವೆಗಳನ್ನು ಅನುಸರಿಸಿ. ಇವು 3 ಉಚಿತ ಮತ್ತು ನಂತರ ಪಾವತಿ ಸೇವೆಗಳನ್ನು ಒಳಗೊಂಡಿರುತ್ತವೆ.

आपना बाइक बिल्कुल ठीक चलाए रखने के लिए, कृपया आवधिक रखरखाव सेवाओं का पालन करें जिसमें **3 नि:शुल्क और बाद में भुगतान सेवाएं शामिल हैं**, इस पुस्तिका में दिए गए अनुसूची के प्रति।

ଆପଣଙ୍କ ବାଇକକୁ ଉପଯୁକ୍ତ ରିନିଂ ଅବସ୍ଥାରେ ରଖିବା ପାଇଁ ପିରିଓଡିକ ମେନ୍‌ଟେନାନ୍ସ ସର୍ଭିସକୁ ଅନୁସରଣ କରନ୍ତୁ ଯେଉଁଥିରେ ଅନ୍ତର୍ଭୁକ୍ତ ରହିଛି 3 ଟି ମାଗଣା ଓ ପରବର୍ତ୍ତୀ ପେଡ୍ ସର୍ଭିସ୍ ମାଧ୍ୟମରେ ସେବା ପ୍ରଦାନ କରାଯାଇଛି ।

તમારી બાઇકને સંપૂર્ણ ચાલુ સ્થિતિમાં રાખવા માટે, કૃપા કરી નીચે મુજબ સમયાંતરની જાળવણી સર્વિસનું પાલન કરો જેમાં 3 મફત અને પછી યુઝવણી સર્વિસની સમાવેશ થાય છે, આ પુસ્તિકામાં સમાવિષ્ટ સમયક્રમ મુજબ

आपही बाइक ठीक चलती हालत में रखने के लिए, कृपया आवधिक रखरखाव सेवाओं का पालन करें जिसमें **3 नि:शुल्क और बाद में भुगतान सेवाएं शामिल हैं**, इस पुस्तिका में दिए गए अनुसूची के प्रति।

आपाना बाइक खन सठिकभारे चलि थका स्थित बाखिले, अनुग्रह करि नियमिया तदारधान सेवा अनुसवन करिब यात अन्तर्भुक्त थके 3 टि विनाशुलीया आक आब पिखब पविशोध कबा सेवा, एहि पुस्तिकाखनत अन्तर्भुक्त अनुसूची अनुसबि ।

اپنی بائیک کو بہترین رنگ حالت میں رکھنے کے لیے، برائے مہربانی وقت و وقت سے میینٹیننس کی خدمات پر عمل کریں جس میں شامل ہیں: اس کتابچے میں دئے گئے وقت کے مطابق 3 مفت سروسز اور بعد کی پیڈ سروسز۔

## FOREWORD

The logo for the Pulsar N125 motorcycle, featuring the word "pulsar" in a stylized, italicized font with a red underline, and "N125" in a smaller, bold font below it.

Welcome to the Pulsar family! You are now the proud owner of the next generation **Pulsar N125 BS VI** India's No.1 sports bike. By No.1 we are talking about unparalleled performance, superior technology and incredible market leadership that Pulsar today enjoys. This makes the Pulsar you ride, unbeatable and unchallenged both on and off the road. Before you ride out, please read this Owner's Manual carefully and familiarize yourself with the operating mechanism, controls and maintenance requirements of your Pulsar. This will ensure you a safe and trouble free ownership experience. To keep your bike in perfect running condition and deliver consistent performance, we have specially programmed the periodic maintenance services which includes 3 free services and subsequent paid services, as per the schedule contained in this booklet. We earnestly advise you to avail all these services at any of our Bajaj Dealers, who are well equipped with all necessary facilities / genuine parts / oil and trained manpower to ensure the best care for your Pulsar. Your **Pulsar N125 BS VI** comes with a warranty of **5 Year or 75 000 km**, whichever occurs earlier from the date of sale. For details please refer to "Warranty : Scope and Limits" given in this manual.

Should you require any additional information feel free to contact us on helpline numbers or e-mail us at: [customerservice@bajajauto.co.in](mailto:customerservice@bajajauto.co.in) or visit the Bajaj Auto website **[www.bajajauto.com](http://www.bajajauto.com)**. To be a part of the Pulsarmania, visit **<https://www.bajajauto.com/bikes/pulsar>** and follow Pulsar on Instagram at **@mypulsarofficial** Rev up, shift gears and enjoy the Pulsar experience...

**SERVICE DEPARTMENT  
BAJAJ AUTO LIMITED**

## TABLE OF CONTENTS

*pulsar*  
N125

### Description

1. Technical Specifications	1
2. Identification Data	4
3. Location of Parts	5
4. Steering cum Ignition lock	6
5. Fuel Tank Cap	7
6. Instrument Cluster Details	8
7. Instrument Cluster Setting	14
8. Bajaj Ride Connect	16
9. Control Switches	18
10. Idle Start Stop Feature (IDSS)	20
11. Pillion Seat / Tool kit	21
12. Front Seat / Battery / Fitment of Front & Pillion Seat	22
13. Daily Safety Checks	23
14. How to ride your Bike	24
15. Safe Riding Tips	27
16. Engine Oil	28
17. Tubeless Tyre & Tyre Pressure	29
18. Battery	30
19. Periodic Maintenance Information	31
20. Brake Fluid	33
21. Vehicle Cleaning and Washing Care	34
22. Free Service Guidelines	35
23. Periodic Maintenance & Lubrication Chart	36
24. Non Use Maintenance	44
25. Delivery Certificate	45
26. Warranty : Scope & Limit	46
27. Battery Warranty Card	49

### Safety and Warning information :

#### Warning :



This indicates that a potential hazard or injury to you or other persons & to the vehicle can happen if advice provided is not followed.

#### Caution :



This indicates that a potential hazard that could result in vehicle damage. Follow the Advice provided with the caution.

#### Notice:

The description and illustration in this booklet are not to be taken as binding on the manufacturers. The essential features of the type described and illustrated herein remaining unaltered. Bajaj Auto Limited reserves the right to carry out at any moment without being obliged to bring this booklet upto-date & to do modifications on the vehicle, parts or accessories as may be convenient and necessary.

## TECHNICAL SPECIFICATIONS

*pulsar*  
N125

Parameter	Specifications
Engine	4 Stroke, Single Cylinder
Bore x Stroke	54 mm x 54.4 mm
Engine Displacement	124.59 cc
Compression Ratio	9.8 :1
Idling Speed	1400 ± 100 rpm
Max. Net Power	8.83 kW (12 PS) @ 8500 rpm
Max. Net Torque	11 Nm at 6000 rpm
Ignition System	DC
Fuel System	Fuel Injection System
Spark Plug	1 No.
Spark Plug Gap	0.8 ~ 0.9 mm
Lubrication	Wet sump forced Lubrication
Transmission	5 speed constant mesh
Gear Shifting Pattern	1 Down 4 Up
Engine Cooling	Air cooled
Starting Aid	Integrated starter generator (ISG) - Electric & Kick start.
Front & Rear Brake	Disc / Drum brake

## TECHNICAL SPECIFICATIONS

*pulsar*  
N125

Parameter	Specifications
Fuel Tank Capacity	
Full	9.5 L (No Reserve)
Dimensions	
Length	1965 mm
Width	740 mm
Height	1100 mm
Wheel base	1290 mm
Ground Clearance	198 mm
Tyre & Tyre Pressure	
Front Tyre	80/100-17 M/C 46P, Tubeless
Rear Tyre	110/80-17 M/C 57P, Tubeless
Front	1.75 kgf/cm <sup>2</sup> (25 PSI)
Rear (Solo)	2 kgf/cm <sup>2</sup> (28 PSI)
Rear (with pillion)	2.25 kgf/cm <sup>2</sup> (32 PSI)
Electrical System	12 V DC
Battery	12 V 4 Ah VRLA
Head Lamp	LED
Tail / Stop Lamp	LED

## TECHNICAL SPECIFICATIONS

*pulsar*  
N125

Parameter	Specifications
Side Indicator	10W Bulb
Position Lamp	LED
Turn Signal Indicator	LED-Green
Neutral Indicator	LED-Green
Hi-Beam Indicator	LED-Blue
Speedometer Illumination	Reverse LCD (Monochrome)
Fuel Level Indicator	Display on LCD - Bar
Malfunction Indicator	LED-Amber
Idle Start Stop (IDSS)	LED-Green
Service Reminder	Display on LCD
Side Stand Indicator	Display on LCD
Generic Alarm	Display on LCD
Gear Position Indicator	Display on LCD
Rear No. Plate Lamp	12 V, 5W Bulb
Horn	12 V DC
Vehicle Kerb Weight	125 kg.
Vehicle Gross Weight	275 kg.

Note : • All dimensions are under UNLADEN condition. • Above information is subject to change without any notice.  
• This vehicle complies to BS VI standards. • AHO / DRL is government regulation.

## IDENTIFICATION DATA

*pulsar*  
N125

The frame & Engine serial numbers are used to register the motorcycle. They are the unique Alpha-Numeric codes to identify your particular vehicle from others of the same model & type.

### Frame Number Location

On RH Side of Steering Tube  
(Alpha-Numeric - 17 Digits)

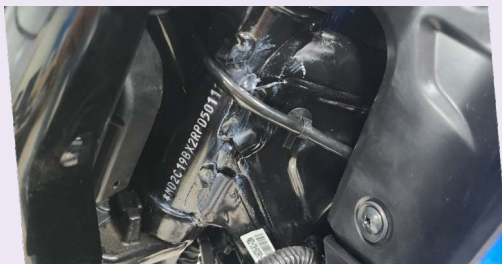

### Engine Number Location

On LH Side Crankcase Near Change lever  
(Alpha-Numeric - 11 Digits)





## LOCATION OF PARTS

*pulsar*  
N125

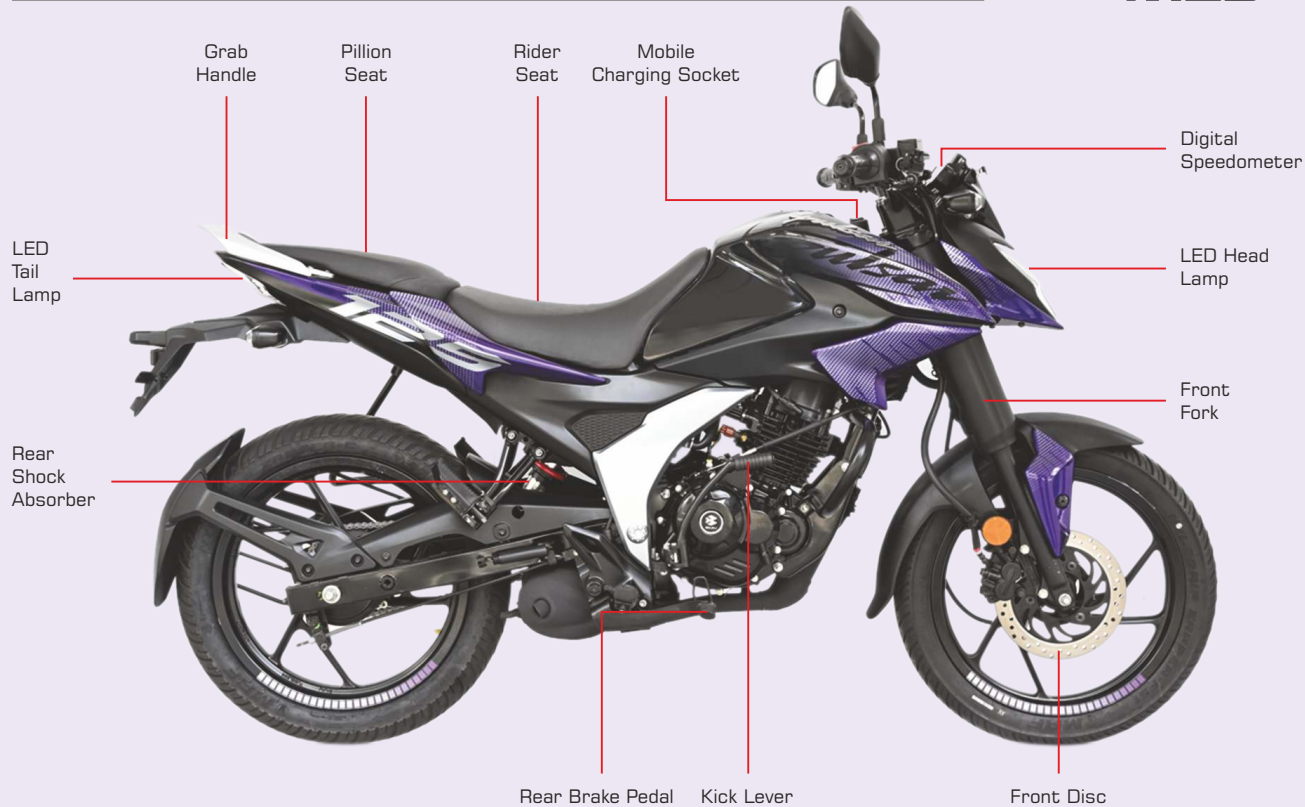

## STEERING CUM IGNITION LOCK

*pulsar*  
N125

### Steering cum Ignition Lock :

It has three positions



- **Lock** : Steering locked. Ignition OFF.
- ⊘ **OFF** : Steering unlock. Ignition OFF.
- ⊘ **ON** : Steering unlock. Ignition ON.

### To lock the steering :

Turn the handle bar to the left side. Push & Rotate the key to "LOCK" Position & Remove the key.

**To Unlock the Steering:** Insert the key in steering cum ignition lock. Push & Rotate it clockwise to "OFF" or "ON" position.

**Key:** A common key is used for 'Steering cum Ignition lock', 'Fuel tank cap' & 'Rear Seat'.

### "Cranking ON and OFF duration" control:

- During Engine crank cycle cranking is allowed only for fixed duration and in between successive cranks (in case engine does not start) here is a cooling off period.
- Cranking on-off duration control feature to avoid battery discharge-
  - 1st Crank ON (5 sec) & Disable for 2 sec.
  - 2nd Crank ON (5 sec) & Disable for 2 sec.
  - 3rd Crank ON (5 sec) & Disable for 15 sec.

After a gap of 10 sec cranking cycle continues.

- Headlight control on rpm – Headlamp will be turned ON only at Engine running condition.



### Fuel Tank Cap

- To open the fuel tank cap, open the flap. Insert the key in the lock & turn it clockwise & lift fuel tank cap.
- To lock the 'Fuel Tank Cap' insert the key in the lock and turn it clockwise and press fuel tank cap from top giving thumb pressure on top surface. 'Click' sound ensures cap is fully locked.



### Caution:

- While operating fuel tank cap do not give pressure on tank cap flap.
- Don't attach metallic 'Key Chain' as it may damage paint of petrol tank cover.

### SOP to prevent fuel stains on petrol tank

- After petrol refilling & before shutting the cap wipe the spilled petrol from the painted areas around the cap by soft dry cotton cloth.
- Shut and lock the cap fully.
- This practice needs to be followed to maintain the shine of color on petrol tank.

### Glossy Finish Painted Parts Cleaning

#### Do's:

- Use Colin or caustic free detergent solution for cleaning.(1 spoon in ½ bucket)  
Remove foreign substances like insect remains, road debris using a soft brush.
- Use microfiber cleaning cloths Ex.- Muslin cloth for painted parts cleaning.
- Use recommended 3M polish.

#### Don'ts:

- Do not use products that are even mildly abrasive, such as polishes, glazes, or rubbing compounds.
- Do not use mechanical cleaners/polishers.
- Do not use terrycloth or paper towels or shine enhancement products.
- Do not rub the finish vigorously, this will burnish the paint finish, causing a permanent shiny spot. Shiny spots cannot be removed.

# INSTRUMENT CLUSTER DETAILS

*pulsar*  
N125

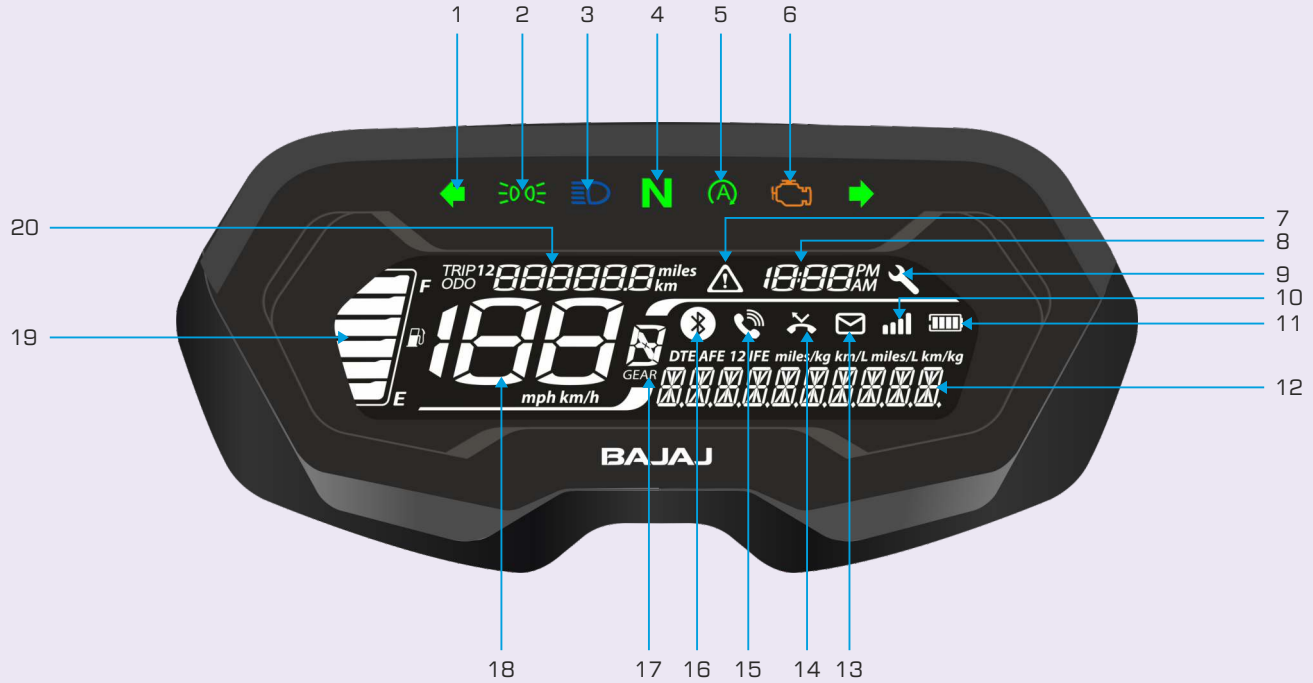

**Speedometer display will work when Ignition switch is in 'ON' position and Kill switch in "ON" position.**

1. **Turn Signal Indicator (↔):** When Turn signal switch is pushed to Left or Right, Turn Signal Indicator - LH or RH will flash.
2. **Position lamp Indicator (⤵⤴):** It Indicates Position lamp is ON.
3. **High Beam Indicator (⦿):** It glows when Headlight is ON & High beam is selected with engine running.
4. **Neutral Indicator (N):** When the transmission is in Neutral, Neutral indicator will glow.
5. **IDSS Indicator (A):** Idle Start Stop (IDSS) system automatically turns off the engine when the vehicle stops at a stop light or other brief stops where vehicle would normally idle for a few seconds.
6. **Malfunction Indicator (H):** It glows whenever any abnormality is noticed in functioning of FI system related components.
7. **Generic Alarm (Δ):** It glows whenever any abnormality is noticed in functioning of ISG system related components.
8. **Digital Clock:** It indicates time in HH:MM (AM/PM).
9. **Service Reminder (Wrench):** 'Wrench' symbol glows when ODO meter reading reaches to set Kms. It indicates vehicle is due for periodic service.
10. **Smartphone Network Range:** It will display network of your smartphone on instrument cluster of your vehicle when connected via bluetooth.
11. **Smartphone Battery level:** If your smartphone is paired with the instrument cluster of the vehicle via bluetooth, then it will display battery level of your smartphone on instrument cluster.
12. **Multi Information Display:** It displays various information, such as Instantaneous Fuel Economy (IFE), Distance to Empty (DTE), Average Fuel Economy (AFE) for Trip 1 or Trip 2, Caller's name/mobile number during call, warning messages.
13. **Message Alert:** If your smartphone is paired with the instrument cluster of your vehicle via bluetooth, then you will get the message alert on the instrument cluster. The incoming message alert icon will blink for 6 seconds. Post 6 seconds, message alert icon will display steady "ON".  
If the ignition key is turned "OFF" and then "ON" text message indication will disappear until a new message is received.
14. **Missed Call Alert:** If your Smartphone is paired with the instrument cluster of the vehicle via bluetooth, then you will get the missed call alerts on the instrument cluster.

- 15. Incoming Call Alert:** This icon will become active and displayed blinking when there is incoming call and display steady "ON" only when call is received (If your smartphone is paired with the instrument cluster of the vehicle via bluetooth). While receiving a call, the caller's name/ mobile number will be displayed at bottom multi-information display area. Call accept/ reject with the help of Mode button on control switch LH.
- 16. Bluetooth icon on Instrument cluster:** It displays status of your smartphone pairing with your vehicle. When the ignition key is turned "ON" bluetooth icon will blink for 10 seconds. Post that bluetooth icon will disappear, but will be active in background for pairing with smartphone.  
Bluetooth icon steady: Paired with smartphone.
- 17. Gear Indication (  ):** It will display gear position from 1 to 5. It will display N when vehicle is in neutral position.
- 18. Speedometer:** Vehicle speed will be displayed in digital form in km/h.
- 19. Fuel level indication:** It indicates available fuel in fuel tank. Instrument cluster shows warning messages in case of low fuel level.  
**Fuel level sensor OPEN condition:** "E, F & Fuel boundary" all three blinks.  
**Fuel level sensor SHORT condition:** "E, F, Fuel boundary & all fuel bars" all four blinks.

**20. Odometer / Trip Meter:** The odometer shows the total distance that the vehicle has covered. Odometer cannot be reset to 'Zero'.

Trip 1 & Trip 2 shows the distance traveled since it was last reset to zero.

### Instrument Cluster automatic brightness adjustment:

Instrument cluster brightness intensity is based on current clock time. During day time brightness will be high while on night brightness will be low.

Ensure correct clock time in instrument cluster.

Refer below table for the intensity change as per given clock time.

Clock time	Day/ Night Mode	Intensity level
6:00 am - 6:00 pm	Day mode	High
6:01 pm - 5:59 am	Night mode	Low

**Note :** After switching 'ON' the ignition switch, the following indications will remain 'ON' till engine is started.

- Malfunction Indicator.

**Instructions :** In case Malfunction indicator, Generic alarm gets ON during vehicle running, bring the vehicle nearest BAL authorised workshop for inspection/repair.

## INSTRUMENT CLUSTER DETAILS - IFE & ODO

pulsar  
N125



### Condition

Ignition switch is ON & Mode push button not pressed. Following display will be shown by digital instrument cluster.

1. **IFE (Instantaneous Fuel economy):** This will indicate fuel economy in km/L. at any given time. Value will be displayed only when vehicle speed & Engine rpm is more than zero.  
If vehicle speed is zero then IFE will be displayed "-- km/L"
2. **ODO:** The Odometer shows the total distance that the vehicle has travelled.

3. **Fuel Level Indicator:** Fuel level is shown by digital LCD bars with (E) empty, (F) full & ( ) fuel tank LCD symbol.  
Low fuel level icon blinks if number of bars on the fuel gauge is 1 bar or less.

### Note:

IFE (Instantaneous fuel economy) / AFE (Average fuel economy) / DTE (Distance to empty) readings are indicative & may vary due to driving and road conditions.



**Procedure to set AFE 1 & TRIP 1:**

Ignition switch is ON, Kill switch is ON & Mode push button pressed for less than 1 sec. - TRIP 1 mode gets selected & following display will be shown by digital instrument cluster:

1. **AFE 1 (Average Fuel economy 1):** This will indicate the average fuel economy in km/L in TRIP 1 mode.
2. **TRIP 1:** The Trip meter shows the total distance that the vehicle has travelled in TRIP 1 mode. If TRIP 1 is reset, average fuel economy (AFE 1) will reset.

**Procedure to set AFE 2 & TRIP 2:**

Ignition switch is ON, Kill switch is ON & Mode push button pressed for less than 1 sec. - TRIP 2 mode gets selected & following display will be shown by digital instrument cluster:

3. **AFE 2 (Average Fuel economy 2):** This will indicate the average fuel economy in km/L. in TRIP B mode.
4. **TRIP 2:** The Trip meter shows the total distance that the vehicle has travelled in TRIP 2 mode. If TRIP 2 is reset, average fuel economy (AFE 2) will reset.

**Note:** AFE will be updated every 60 sec. AFE will be reset if corresponding TRIP 1 or TRIP 2 is reset or battery disconnected.



## INSTRUMENT CLUSTER DETAILS - DTE & TRIP

*pulsar*  
N125

### DTE (Distance to empty):

It indicates the estimated distance that the vehicle can travel under current fuel economy & fuel level condition.

DTE calculation is independent of TRIP and based on AFE for distance covered for last 25 km.

Max count of DTE is 990 km. speedometer will display values in multiple of 10.

### Note:

IFE & DTE both are displayed at "Multi information display". When IFE is displayed, press Mode button for more than 3 seconds - DTE gets displayed in place of IFE.



### TRIP Setting:

If Mode button is pressed more than 3 sec. in TRIP 1 or TRIP 2 mode, then respective AFE & trip distance will reset to Zero while DTE will continue to show earlier value.

### Note:

After completion of max value of 999.9 km, selected trip display will get freezed and will not get set automatically to zero.

However speedometer will continue to calculate and display AFE value.

### Note:

If vehicle is driven by ignoring fuel level display & Tank symbol (  ) blinking after reaching fuel unutilized level DTE will be shown as '--' km.

### During Petrol Refilling:

If petrol filled is more than 1 L then DTE will be calculated based on the revised fuel volume.

If petrol filled less than 1 L then there will be no change in DTE value.

## INSTRUMENT CLUSTER SETTING

*pulsar*  
N125



### 1. Trip Meter Reset:

Mode push button is provided for selecting & resetting "ODO/ TRIP 1/ TRIP 2".

- |  |  |
|--|--|
| 1. Press Mode button for less than 1 sec.      | Mode changes from "ODO/ TRIP 1/ TRIP 2".                                     |
| 2. Press Mode push button for more than 3 sec. | Selected TRIP 1/ TRIP 2' will reset. Other TRIP mode will continue updating. |

**2. Service Reminder Reset (  ):** 'Wrench' symbol glows when ODO meter reading reached to set km.

### This icon will glow at-

- |               |                |
|---------------|----------------|
| 1st : 450 km  | 2nd : 4450 km  |
| 3rd : 9450 km | 4th : 14450 km |
- & subsequently at each 5000 km.

**Note:** This icon shall be reset by BAL authorised workshop after periodic services are carried out.



### 3. Clock Reset:

- Digital clock indicates time in HH & MM separated by colon ':' It is 12 hour clock.
- For entering clock setting mode - press Mode, go to "CLOCK" & press Mode button for more than 3 sec.

Speedometer enters in clock resetting mode.	HH digits starts blinking.
Press Mode button for less than 1 sec.	Hour digits will increase.
Press Mode button for more than 3 sec.	HH value will be stored while MM starts blinking.
Press Mode button for 1 sec.	Unit digit of Minute will increase.
Press Mode button for more than 3 sec.	Unit digit will be stored, modify Tenth digit of minute clock M.
Press Mode button for more than 3 sec.	Minutes value will be stored. AM & PM starts blinking
Press Mode button for 1 sec.	Select AM/PM.
Press Mode button for more than 3 sec.	All blinking stops and clock show the selected value of HH:MM AM/PM.
Clock set mode is selected & no ending is carried out for more than 5 sec.	Auto exit without saving set value. If engine / vehicle rpm is given then system will exit from clock set mode without saving set value.

## Mobile Charger

- Mobile charging socket has been provided on fuel tank cover
- The charger socket has been provided with cap to protect charger socket from dust & water entry during washing / during rain.
- Always ensure charger cap is firmly fitted on socket when charger socket is not in use.

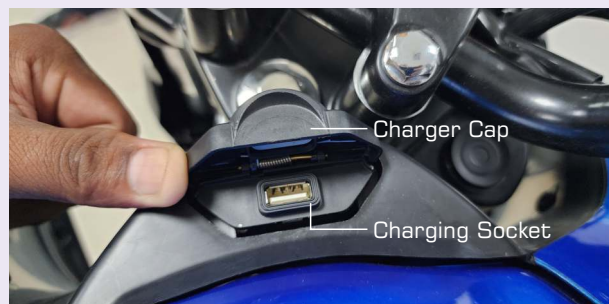

- The mobile charger will supply output voltage only in engine running condition.
- Customer to use suitable USB cable for mobile charging.



### Caution:

Do not use mobile phone while driving. Momentary lapse in concentration might result in an accident.

### Bajaj Ride Connect Application:

“Bajaj Ride Connect” Application is based on bluetooth connectivity with the instrument cluster. This app offers a range of features, including vehicle management, service booking, document storage and more. With seamless bluetooth connectivity to Pulsar, the app ensures a personalized and convenient riding experience for every register user.

Key features of the application:

**Bluetooth:** once connected to the vehicle through the application user can access below bluetooth features:

- Call Accept/ reject with the help of Mode button on control switch LH.
- Smartphone battery level.
- Smartphone network range.
- Missed call.
- Message alert.

### Service:

- Book service appointment for relevant service type.
- Locate nearby BAL workshop location.

**Document storage:** Important vehicle related documents, such as insurance paper and registration certificates, can be securely stored within the app, providing easy access whenever needed.

 **Caution:** Document storage works as a digital wallet and is only for storage purpose.

**Reminders:** Users can set reminder for vehicle maintenance, service schedules, insurance renewals and other important tasks.



## Application download:

Bajaj ride connect application is available in the Google play store (for android) or Apple store (for iOS).

- Download the “Bajaj Ride Connect” App from Google play store/ Apple store.
- Click on “Sign up” to register in the App with your registered mobile number.
- Enter your personal details (first & last name).
- Enter VIN of your vehicle (VIN can also be scanned).
- Click on “Sign up”.
- Enter OTP.
- Login in App
- “Bajaj Ride Connect” App is ready to work.

## Bluetooth connectivity:

Your vehicle is equipped with bluetooth connectivity feature by which you can pair your smartphone with instrument cluster of your Pulsar vehicle through “Bajaj ride connect” application.

- Turn the ignition switch and kill switch “ON”.
- Login “Bajaj ride connect” application on your smartphone.
- For first time pairing, allow the application to access:
  - a. Device’s location if GPS is not enabled in your device
  - b. Access your phone called logs.
  - c. Send and view messages.
  - d. Notification’s

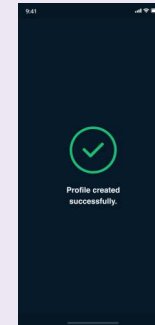
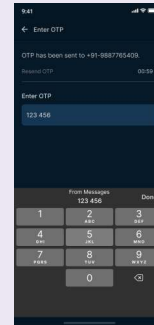
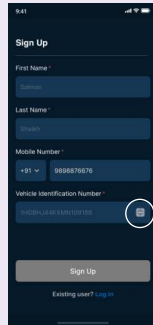
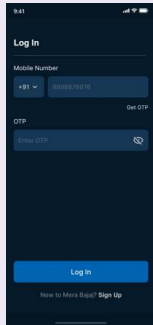

## CONTROL SWITCH LH

*pulsar*  
N125



- 1. Mode Button:** Mode button is used for:
  - Call Accept/ Reject.
    - Call accept: Press Mode button for less than 1 sec.
    - Call reject: Press Mode button for more than 3 sec
  - To toggle between Trip 1, Trip 2, IFE, Instrument cluster setting, Clock setting etc.
- 2. Turn Signal Switch:** When the turn signal knob is turned to Left (←) or Right (→) respective indicator will start blinking, to stop blinking push the knob in & release.
- 3. Horn Button (📢):** Press button for sounding horn.
- 4. Pass Switch :** Press the switch to put 'ON' Hi Beam/Low Beam/Pass light.

It is used to give signal to vehicles coming from opposite side while overtaking.

When headlight is ON, High or Low beam can be selected with this switch. Hi beam indicator light located on Speedo console will light up when high beam is selected.

☰☉: High Beam

☰☉: Low beam

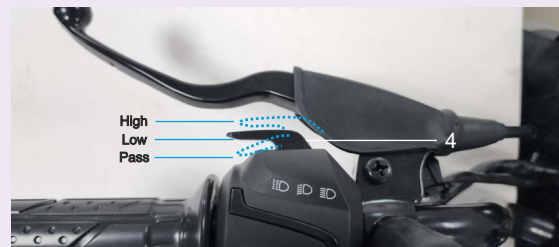

Switch Position & H/L status			
Switch position	Hi Beam Switch	Low Beam Switch	Pass Beam Switch
Headlamp Beam status	☰☉ Headlamp Beam	☰☉ Low Beam	☰☉ Pass Beam

**⚠ Warning :** Always use the appropriate turn signal indicators when you intend to change lanes or take turns. Be sure to switch it 'OFF' after negotiating the lanes or turns. Use appropriate head lamp beam 'high / low' as per the traffic and road conditions for your safety & to avoid inconvenience to other riders.

## CONTROL SWITCH RH

*pulsar*  
N125



### 5. Starter Button:

Starter button operates the electric starter. It is recommended to start the engine with the transmission in neutral.

Vehicle in Gear - Press clutch lever & operate starter button to start the engine.

### 6. Engine Kill Switch:

The engine kill switch is used for switching ON & OFF the engine. :

⊗ : Engine OFF

⊙ : Engine ON

**7. IDSS Switch:** IDSS switch is used to enable / disable the idle start stop feature. It has 2 positions.

⊗ : IDSS OFF

⊙ : IDSS ON

### AHO (Automatic Headlight 'ON')

There is no 'Light Switch' on RH control switch.

Ignition switch 'ON' Engine 'OFF'	Speedometer will get 'ON'
Effect of pressing 'Pass switch'	In addition to above Hi-beam will get 'ON' & high beam indicator will get ON

### Ignition switch 'ON' & Engine Running:

Speedometer illumination, tail lamp, number plate lamp, pilot lamp will get 'ON' in addition to above, head lamp will get ON as given below

Hi/Low Beam switch	Head Lamp Beam Status	Effect to Pass Switch
Low Beam ⊙	Low Beam 'ON'	Hi Beam 'ON'
Hi beam ⊗	Hi beam 'ON'	No change

## IDEAL START STOP FEATURE (IDSS)

*pulsar*  
N125

Idle Start Stop (IDSS) system automatically turns off the engine when the vehicle stops at a stop light or other brief stops where vehicle would normally idle for a few seconds. This system works only in Neutral gear with clutch lever released condition. Restarting of the engine happens automatically based on pressing of clutch lever from rider. This benefits in fuel savings and reduced emissions.

### Preconditions:

- IDSS switch should be in ON condition and vehicle speed should be >5 kmph.
- The engine should be warmed up and healthy battery voltage is required.
- When above conditions are met Idle Start Stop function gets enabled.
- When enabled tell-tale will change from OFF→Steady ON in instrument cluster.



### Auto Engine Stop:

After above preconditions are met, following conditions are checked by system when a ride is completed and vehicle is brought to stationary condition.

- Speed = 0 kmph
- Gear position = Neutral

- Throttle Position = 0%
- Clutch lever = Released

When all above conditions are met, tell-tale starts blinking for few seconds and engine stops automatically.

When engine stops, tell-tale becomes steady ON again indicating that IDSS system is active.

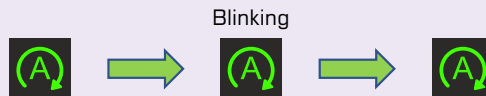

### Auto Engine Restart:

When engine is in "Auto Stop" mode and rider wants to restart, pressing of clutch lever is required.

Once engine is restarted, tell-tale in instrument cluster will become OFF indicating that IDSS cycle is completed.



### Note

- 'IDSS' switch can be selected (On or OFF) at any point of driving cycle time.
- Vehicle can be started at any point of time using electric start when the engine is in stall condition and the ignition key is in 'ON' condition.





### Removal of Pillion Seat

- Insert Key into lock (A).
- Turn the key clock wise.
- Lift front end of 'Pillion seat'
- Pull 'Pillion seat' toward front side.
- Take out 'Pillion seat'.

### First Aid kit Location

- It is located on RH side of seat cowl below pillion seat.



### Tool Kit Location

- It is located between battery & seat lock.

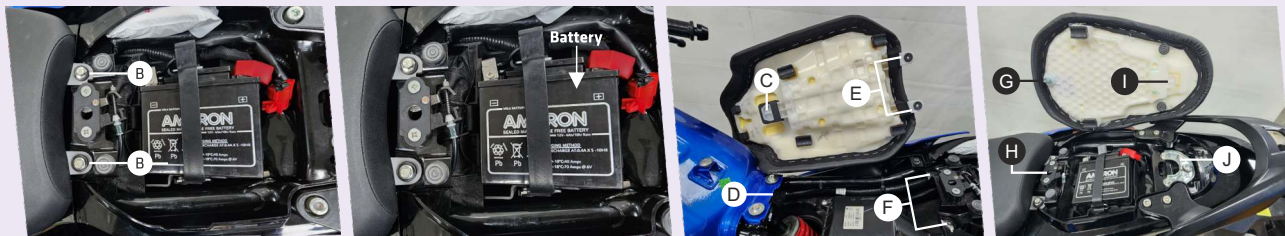

### Removal of Front Seat

- First remove 'Pillion seat'.
- Remove 'Front seat' mounting bolts (B).
- Pull backward rear end of 'Front seat'.
- Take out 'Front seat'.

### Battery

- It is located below pillion seat.

### Fitment of 'Front Seat'

- Match the lugs of 'Front seat' (C) with chassis bracket (D).
- Push 'Front seat' towards petrol tank.
- Match 'Front seat' rear brackets (E) with the holes provided on chassis (F).
- Tighten the bolts.

### Fitment of 'Pillion Seat'

- First make sure 'Front seat' is fitted properly.
- Match the bracket of 'Pillion seat' (I) with Hook (J).
- Insert lock rod (G) of seat into seat lock (H).
- Press front portion of seat.

Before riding motorcycle be sure to check following items. Please give proper importance to these checks & perform all of them before riding motorcycle. If any irregularities are found during these checks, refer to the Maintenance chapter & see your dealer for the action required to return the motorcycle to a safe operating condition.

 **Warning:** Failure to perform these checks every day before you ride may result in serious damage or severe accident.

- Enough **fuel level** for planned distance of journey. No fuel leakage in fuel lines.
- **Engine oil** level (between upper and lower level mark).
- **Throttle cable** play of 2 - 3 mm. Smooth operation and positive return to closed position.
- **Brake Fluid** level above MIN mark provided on Front reservoir.
- **Drive Chain** slack of 20-30 mm adequately lubricated.
- Function of all lights & horn.
- **Clutch lever** play - 2 to 3 mm.
- Smooth **steering movement** without restriction.
- **Side stand** return to It's fully up position.
- Correct **inflation pressure** in both tyres. Adequate tyre tread depth - no cracks / cuts.
- Correct **rear viewing** span adjustment of mirror.

- Cleaning cloth not to be kept in vicinity of high temperature zone e.g. Engine, silencer assembly, starter motor etc.
- Cleaning cloth to be kept in LH/RH seat cowl.

### Instructions for Customer

- There is no fuel cock.
- Always maintain minimum 3 L petrol in fuel tank.
- Use only recommended engine oil and fuel system parts cleaner.
- If vehicle is tilted beyond 60 Deg, then Roll over sensor cuts off Ignition system as a safety feature.
- Never drive by disconnecting wheel speed sensor.

### E20



- This vehicle is compatible for "E20" Petrol i.e. Petrol blended with 20% Ethanol. E20 sticker affixed on fuel tank cap.
- In this vehicle 'E10' Petrol (existing) i.e. Petrol blended with 10% Ethanol also can be filled.

### 1. Starting The Engine:

- Ensure minimum 3 L petrol is available in fuel tank.
- Turn ignition switch key to 'ⓐ' position.
- Put kill switch in 'Q' position.
- Confirm that transmission is in neutral / press the clutch lever if transmission is in gear.
- Keep throttle closed & press starter button,
- Release starter button as soon as engine starts.

### “Cranking ON and OFF duration” control –

Cranking ON-OFF duration control feature to avoid battery discharge-

- 1st Crank ON (5 sec) & Disable for 2 sec.
- 2nd Crank ON (5 sec) & Disable for 2 sec.
- 3rd Crank ON (5 sec) & Disable for 15 sec. After a gap of 10 sec cranking cycle continues.

### Note :

- The motorcycle is equipped with a clutch switch. This switch facilitates engine starting in neutral and gear position.

Gear Position	Clutch lever position
Neutral	Released
Gear	Fully pressed

- In case of battery discharged condition please bring the vehicle to bajaj authorised workshop for repairs.

### 2. Shifting Gears:

- Close throttle and press the clutch lever fully.
- Shift into next higher or lower gear.



Gear Shifting Lever

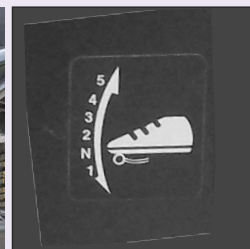

Gear Shifting Pattern

### 3. Moving Off:

- Check that side stand is up.
- Press the clutch lever.
- Shift into 1st gear.
- Open the throttle and release the clutch lever slowly and simultaneously.
- As the clutch starts to engage, open the throttle a little more, giving the engine just enough rpm to keep it from stalling.

## Recommended Speed for Shifting Down

From 5th to 4th Gear	45 km/h
From 4th to 3rd Gear	35 km/h
From 3rd to 2nd Gear	25 km/h
From 2nd to 1st Gear	15 km/h

 **Warning:** When shifting down to lower gear, do not shift at such high speed that engine rpm jumps excessively. This may cause engine damage, & rear wheel may skid. Downshifting should be done at recommended speeds as shown in table above.

### 4. Braking & Stopping the Vehicle:

- Close the throttle completely, leaving the clutch engaged (except where shifting gears) so that the engine braking will help slow down the motorcycle.
- Shift down one gear at a time so that you are in Neutral when you come to a complete stop.
- When stopping, always apply both brakes at the same time.

### 5. Parking Using Side Stand:

- Support the motorcycle on a firm level surface with the side stand.

 **Caution:** Do not park on a soft or steeply inclined surface as the motorcycle may fall over.

## 6. Running IN

Proper running-in is important for the better life & trouble free performance of the vehicle.

- During first 2000 km running-in period do not exceed following speed limits.

km	1st	2nd	3rd	4th	5th
0-1000	10	20	30	35	45
1000-2000	15	30	40	45	55

- Always keep speed below the limits given in table.
- Do not race the engine excessively.
- Do not start moving or race the engine immediately after starting. Run the engine for a minute at idle speed to give the oil a chance to work up into the engine.

 **Caution :** Always ensure side stand is UP while starting off. Under condition-side stand down & vehicle is in gear, self start will be disabled. 'side stand' Indication will be displayed in speedometer.

- Do Not REV engine in standstill condition.
- Always maintain engine oil between upper & lower mark at vehicle upright position on level surface.
- Always maintain Brake Fluid is above MIN mark on front brake reservoir keeping vehicle in upright position on level surface.

Ensure following maintenance points to get optimum performance from your bike.

Fuel	Always maintain minimum 3 L Petrol in fuel tank.
Spark Plug	Inspect and clean spark plug. Adjust electrode gap. Replace spark plug as per P.M. chart.
Air Filter	Replace as per Periodic Maintenance Chart.
Engine Oil	Check engine oil level. Always use recommended grade and quantity.
Brakes	Ensure that the brakes are not dragging / binding.
Clutch	Ensure correct clutch lever play.
Tyre Air Pressure	Always maintain recommended tyre air pressure.
Brake Fluid	Always maintain brake fluid level above minimum mark. Ensure no leakage of brake fluid in brake system.

### Fuel Saving Tips:

A well maintained vehicle and good driving can contribute a lot to the saving of petrol. Following are a few simple fuel saving tips.

- Avoid harsh braking.
- Change the gear judiciously according to the speed and load requirement.
- Don't overload the vehicle above the specified payload.
- Use the accelerator judiciously.
- Cut off the engine if you want to stop for more than two minutes.

### How to check mileage (Fuel efficiency)

Best way to calculate mileage is by following the full tank to full tank method.

- Fill fuel tank up to small mouth (brim).
- Run the bike for say 100 km.
- Fill the tank again up to small mouth (brim). In same fuel filling station, probably with same fuel dispenser.
- Divide kilometer run / fuel quantity filled.

## SAFE RIDING TIPS



- Always wear Helmet while driving or riding. Your helmet should conform to Indian standards.
- Read thoroughly the instructions given in this manual and follow them carefully.
- Avoid unnecessary accessories for the safety of both rider and other motorists.
- Familiarise yourself well with starting, acceleration and braking of the vehicle.
- When applying the brakes, use both front & rear brakes simultaneously. Applying only one brake may cause the vehicle to lose control.
- Riding at proper speed, avoiding unnecessary acceleration and braking are important safety, fuel consumption and longer life of the vehicle.
- During monsoon, drive vehicle more cautiously. Remember vehicle skid more easily during light showers.
- Keep both hands firmly on handle bar & both feet securely on rider footrest. Do not take away both hands & / or feet from resting area as this is very unsafe.
- Do not use mobile phones while riding as it could lead to fatal accident.

- It is suggested to customer to take appropriate care in area of heavy monsoon or high rainfall area. The appropriate surface preventive coat to avoid rusting / poor surface finish on account of adverse atmospheric conditions.
- Always carry vehicle registration & insurance papers, and a valid driving licence with you.

### General Maintenance Tips:

- Vehicle cleaning to be done with soft & clean wet cloth to avoid scratches on painted parts.
- Clean & lubricate all the important parts as detailed in a periodic maintenance chart.
- Do not apply direct water jet on electrical / electronic parts.
- Do not obstruct engine cooling by adding mud protection sheet from front
- Drive cautiously. Start early & reach your destination safely.
- Avoid driving on loose sand or stones where vehicle is likely to skid.
- Properly wrap-up loose clothes while driving or riding to avoid entangling in wheel or other objects on road.
- Always concentrate on riding for safety.

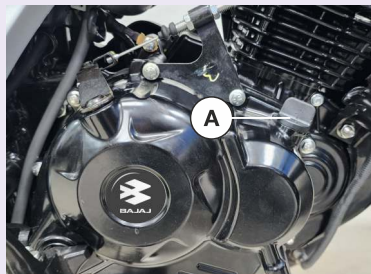

A : Oil Filler Cap



### Engine Oil Level Checking Procedure:

- Idle the engine for 2-3 minutes if engine is cold.
- Switch off engine and wait for 2-3 minutes.
- Park the vehicle on level surface to check oil level.
- Park on center stand.
- Remove dipstick and wipe it clean.
- Insert dipstick until it touches clutch cover surface. Do not screw it.
- Remove dipstick and check oil level.
- Oil level should be between "H and L" mark as per image.

### Engine Oil Capacity:

- Refill at servicing : 1000 ml
- During engine overhaul : 1100 ml

### Recommended Engine Oil:

Always insist on Bajaj Engine Oil for optimum engine performance and warranty benefits. It is a specially formulated oil for Bajaj vehicles.

Model	Recommended Engine oil
<b>Pulsar N125</b>	Bajaj 10W40 <b>BS6 Compliant</b> SAE 10W40 JASO 'MA2' API SJ

- **Engine oil replacement frequency : 1<sup>st</sup> service & then every 10,000 km.**
- **Engine oil level top-up frequency : Every 5000 km.**



**Caution:** It is most important to adhere to recommended grade and frequency of oil change for the purpose of long life of critical engine components. For details refer periodic maintenance chart.



### Tubeless Tyre:

The main advantage of tubeless tyres is in case of puncture the rate of air leak is very slow, hence customer can easily drive the vehicle upto nearest puncture repair shop for removing puncture.



### Wheel Puncture:

- Visit nearest known tubeless tyre repair shop to remove puncture.
- Remove puncture by Filler or Plug method only.
- Do not use patch method to remove puncture of tubeless tyre.



**Caution:** Tubeless tyres are fitted in this motorcycle. The walls of the tyres in contact with the wheel rim should not be damaged in any way during fitment / removal of tyre. The tyre side walls in contact with wheel rim seals air.

### Tyre Pressure:

Keep recommended tyre pressure (refer Technical Specifications) to increase life of the tyre & for better fuel consumption.

- Tyre warranty is settled by tyre manufacturer.
- Decision is taken based on tyre wear & running of vehicle.
- BAL settles tyre warranty for only imported tyres.



### Battery : 12 V - 4 Ah VRLA

- Battery is located below pillion seat.

### Battery Features:

- No topping-up is required
- Reduced self discharge, Enhance safety.
- No vent tube open to atmosphere hence no discharge of electrolyte through vent tube.

 **Caution:** Vehicle will not start if battery is discharged or disconnected from vehicle

- Environment care must be taken to dispose off the used battery.
- It is always recommended to hand over the same to the Authorised battery / BAL dealer for proper disposal of the same.
- When 'Low battery' warning message appears in instrument cluster display, it is advised to reach Authorised battery / BAL dealer & get it charged immediately.
- Warranty on battery is 18 months from the date of purchase of vehicle.

### How to keep battery healthy ?

- Switch 'Off' ignition when engine is not running.
- Get battery checked/ charged during periodic services.
- Do not add extra electrical accessories such as Remote, Bigger Horn, Musical brake light etc. This will reduce life of battery & may damage ECU.
- Disconnect battery +ve & -ve wires if vehicle is to be stored for more than 2 weeks. This avoids self discharge.

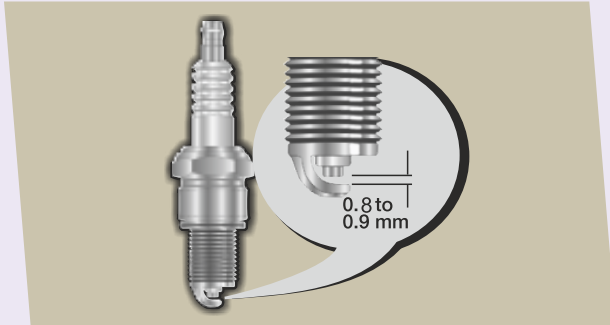

### Spark Plug

- Remove spark plug by using plug spanner.
- Clean the spark plug.
- Adjust the gap if incorrect by bending outer electrode carefully.

Spark Plug Gap : 0.8 to 0.9 mm.

### Drive Chain Slackness

- Chain slackness will have to be adjusted whenever required.
- Std. Chain slackness 20-30 mm in 1st gear or both wheels touching to ground.
- Marking on chain adjusters should be identically positioned on both sides.





**Drive Chain  
Cleaning**

Drive chain must be cleaned & lubricated as per periodic maintenance schedule.

### **Drive Chain (Sealed type)**

- 'O' rings must always be kept wet for best performance hence lubricate at every 500 km.
- Sealed chain lubrication can easily be done by owners using Bajaj 'Chain Lube Spray Can' available with Bajaj dealers.



**Drive Chain  
Lubrication**

### **Method of Sealed Chain Lubrication:**

- Put vehicle on main stand. Clean the chain by using lint free cloth (If excessive mud / slush found approach BAL dealer for proper cleaning).
- Shake the can vigorously by holding vertically upright till the noise of steel ball inside heard uniformly.
- Hold spray can at the back of rear sprocket with extension tube nose at 5-10 cm.
- Rotate the wheel in reverse direction & spray the lube on middle portion of the chain up to full length of the chain.



### Front Brake Fluid Level

- Front brake fluid reservoir is located on RH side of Handle bar.
- To check brake fluid level, Park the vehicle perpendicular to the ground on level surface with handle bar in straight ahead condition.
- Always ensure that brake fluid level is above 'MIN' mark given on inspection window.
- In case of level drop, use only DOT-4 brake fluid (from sealed container) for top up and replacement.

Regular cleaning not only enhances the appearance of your motorcycle but also plays a crucial role in maintaining its performance and extending its life by preventing rust, corrosion, and premature wear. We recommend following the guidelines below:

### **Washing Preparation:**

- Ensure the engine and all hot components have completely cooled.
- Cover sensitive parts such as the muffler tail end, speedometer, headlamp, tail lamp, Indicators and control switches to prevent water entry and avoid damage or fogging.

### **Washing Instructions:**

- Rinse the vehicle with clean water using a low-pressure spray to remove loose dirt and debris.
- Avoid spraying water directly on electrical, electronic components, the Oil cooler, lights, switches, or the muffler.
- Use a neutral pH bike cleaner; avoid harsh chemicals or household cleaning agents.
- Clean surfaces gently with a sponge or soft brush to prevent scratches.
- Rinse and wipe using a clean microfiber cloth, followed by thorough drying with low air pressure.
- Ensure all electrical connections are clean and moisture-free.
- Lubricate the drive chain and other moving parts after washing and drying.

### **Important Do's & Don'ts:**

- Recommended washing pressure is up to 20 bar; maintain a 2-meter distance and avoid directing the jet at any spot for more than 10 seconds to prevent damage to electrical components like LCDs, LEDs, and other sensitive parts.
- Do not spray water into the air cleaner or throttle body, as it may cause starting issues.
- Avoid removing the seat or any other components during pressure washing to prevent water ingress.
- After washing, gently apply brakes at low speed to dry them; clean brake discs or pads if necessary.
- For matte-painted surfaces, avoid using wax or polish. Instead, clean with mild detergent and a soft cloth.

 **Note :** Headlight lenses may temporarily fog up after washing or riding in the rain. This is normal and does not affect functionality. However, if the moisture/water accumulation is high, please visit the nearest BAL dealer for vehicle inspection.

Following these simple steps will help keep your motorcycle in excellent condition and ensure its reliable performance.

## FREE SERVICE GUIDELINES



### Instruction to avail Free Service through Digitized Free Service Coupon

Please follow following procedure : -

- Please provide your mobile number to Dealer at the time of buying of new Bajaj Vehicle.
- In case of change in mobile number, please update to Dealer / ASD.
- When you are at Dealership / ASD workshop for availing Free Service, you will receive the 'Unique Coupon Number' (UCN) through SMS in your mobile.
- Please inform the UCN to Dealer / ASD at the time of Free Service.  
(ASD-Authorised Service Dealer)

Periodic Service Criteria			
Service	Days	km	whichever occurs earlier.
1st Free Service	30~45	500~750	
2nd Free Service	240	4500~5000	
3rd Free Service	360	9500~10000	
Subsequent Paid Services	120 Days from Last Service	Every 5000 km after Previous Service	

Availing all Free / Paid Services, replacing mandatory periodic parts & engine oil will entitle warranty eligibility.

## PERIODIC MAINTENANCE & LUBRICATION CHART



Sr. No.	Activities / Check Points	Recommended frequency - Service interval & km						
		1st (Free)	2nd (Free)	3rd (Free)	4th	5th	6th	7th
		500 ~ 750	4500 ~ 5000	9500 ~ 10000	14500 ~ 15000	19500 ~ 20000	24500 ~ 25000	29500 ~ 30000
1	Servicing with water wash	✓	✓	✓	✓	✓	✓	✓
2	Engine oil (Bajaj DTSI 10000 oil)	R	Top-up	R	Top-up	R	Top-up	R
3	Oil strainer	CL		CL		CL		CL
4	Centrifugal oil filter	CL		CL		CL		CL
5	Air cleaner element** with 'O' ring.				R			R
	Drain tube cleaning.	CL	CL	CL	CL	CL	CL	CL
6	Fuel Pump Nylon hoses with quick connector					C,R		
7	Spark plug clean & check gap			CL,A		CL,A		R
8	Valve tappet clearance	C,A	C,A	C,A	C,A	C,A	C,A	C,A
9	Engine breather tube for cracks.			C,R	C,R	C,R	C,R	C,R
10	EVAP system Hoses- check for cracks					C,R		
11	Silencer drain hole cleaning			CL	CL	CL	CL	CL



## PERIODIC MAINTENANCE & LUBRICATION CHART



Recommended frequency - Service interval & km									Remarks
8th	9th	10th	11th	12th	13th	14th	15th	16th	
34500 35000	39500 40000	44500 45000	49500 50000	54500 55000	59500 60000	64500 65000	69500 70000	74500 75000	
✓	✓	✓	✓	✓	✓	✓	✓	✓	Protect to prevent water entry in Petrol tank, Silencer & electrical parts. Use caustic free detergent for washing.
Top-up	R	Top-up	R	Top-up	R	Top-up	R	Top-up	Use BGO 10W40 BS6 compliant. Replace engine oil in 1st service & at every 10000 km.
	CL		CL		CL		CL		Oil strainer cleaning at the time of oil change.
	R		R		R		R		Clean body centrifugal filter at first free service and then at every 10,000 km.
		R			R			R	Replace air filter at every 15,000 km.
CL	CL	CL	CL	CL	CL	CL	CL	CL	Replace Air filter cover 'O' ring along with air filter
	C,R				C,R				Replace if required
	CL,A		CL,A		R		CL,A		Replace at every 30000 km
C,A	C,A	C,A	C,A	C,A	C,A	C,A	C,A	C,A	
C,R	C,R	C,R	C,R	C,R	C,R	C,R	C,R	C,R	Replace if required. Need to remove RH Side cover. Breather Tube is visible with this cover removed.
	C,R				C,R				Drain EVAP "Y" connection drain tube. Replace if found cut/damaged
CL	CL	CL	CL	CL	CL	CL	CL	CL	

## PERIODIC MAINTENANCE & LUBRICATION CHART



Sr. No.	Activities / Check Points	Recommended frequency - Service interval & km						
		1st (Free)	2nd (Free)	3rd (Free)	4th	5th	6th	7th
		500 ~ 750	4500 ~ 5000	9500 ~ 10000	14500 ~ 15000	19500 ~ 20000	24500 ~ 25000	29500 ~ 30000
12	Wiring harness connections, routine & Conduit / PVC sleeve / Tie band inspection.	C,A,T	C,A,T	C,A,T	C,A,T	C,A,T	C,A,T	C,A,T
13	Battery connections & health by load tester. +ve terminal cap fitment.	C,A,L,T	C,A,L,T	C,A,L,T	C,A,L,T	C,A,L,T	C,A,L,T	C,A,L,T
14	Ignition switch contacts cleaning			CL,L	CL,L	CL,L	CL,L	CL,L
15	HT coil connections					C,T		
16	Starter motor & starter relay connections (For Starter motor version)		C,T	C,T	C,T	C,T	C,T	C,T
17	ISG CU connector connections (for ISG version)	C	C	C	C	C	C	C
18	Check fault code, Clear fault history, Update latest hex file if applicable	C	C	C	C	C	C	C
19	Sealed Drive chain wear** – Clean, lubricate & adjust. Replace if required	CL,L,A	CL,L,A	CL,L,A	CL,L,A	CL,L,A	CL,L,A	CL,L,A

## PERIODIC MAINTENANCE & LUBRICATION CHART



Recommended frequency - Service interval & km									Remarks
8th	9th	10th	11th	12th	13th	14th	15th	16th	
34500 35000	39500 40000	44500 45000	49500 50000	54500 55000	59500 60000	64500 65000	69500 70000	74500 75000	
C,A,T	C,A,T	C,A,T	C,A,T	C,A,T	C,A,T	C,A,T	C,A,T	C,A,T	Damaged conduit / PVC sleeves protection by applying electrical tape film & ensure tie bands to specific location.
C,A,L,T	C,A,L,T	C,A,L,T	C,A,L,T	C,A,L,T	C,A,L,T	C,A,L,T	C,A,L,T	C,A,L,T	Apply petroleum jelly on battery terminals. Use Midtronics battery tester. In case of Battery removal, 1. Battery negative terminal to be disconnected first. 2. Latch seat bracket to be removed.
CL,L	CL,L	CL,L	CL,L	CL,L	CL,L	CL,L	CL,L	CL,L	Use recommended WD40 spray
	C,T				C,T				
C,T	C,T	C,T	C,T	C,T	C,T	C,T	C,T	C,T	
C	C	C	C	C	C	C	C	C	
C	C	C	C	C	C	C	C	C	
CL,L,A	CL,L,A	CL,L,A	CL,L,A	CL,L,A	CL,L,A	CL,L,A	CL,L,A	CL,L,A	During 1st free service use OKS spray for chain cleaning without removing chain from vehicle.
									During other services clean chain with Diesel+SAE 90 oil ratio of 50:50 & lubricate by SAE 90 oil.
									Customer to use OKS chain lub spray at every 500 km

## PERIODIC MAINTENANCE & LUBRICATION CHART



Sr. No.	Activities / Check points	Recommended frequency - Service interval & km						
		1st (Free)	2nd (Free)	3rd (Free)	4th	5th	6th	7th
		500 750	4500 5000	9500 10000	14500 15000	19500 20000	24500 25000	29500 30000
20	Main Stand & Side stand pivot pin					CL,L		
21	Steering play	C,A	C,A	C,A	C,A	C,A	C,A	C,A
22	Steering stem bearing & Cap steering bearing (Plastic)**			C,CL,L		C,CL,L		C,CL,L
23	Front fork oil & seals	C,R	C,R	C,R	C,R	C,R	C,R	R
24	Swing arm NRB for more play							
25	Front brake pad & Rear Brake shoe for wear limit.	C,R	C,R	C,R	R	C,R	C,R	R
26	1. Check source of leakages if any in the brake system.	C,A,R	C,A,R	C,A,R	C,A,R	C,A,R	C,A,R	R
	2. Check Front brake hose condition.							
	3. Check Brake fluid level and top up, if needed.							
27	Rear sprocket fasteners for looseness.	C,T		C,T		C,T		C,T
28	Rear wheel rubber shock dampers for excess play.			C,R		C,R		C,R
29	Clutch & Throttle cable free play adjustment	C,A	C,A	C,A	C,A	C,A	C,A	C,A
30	Head light focus adjustment	C,A	C,A	C,A	C,A	C,A	C,A	C,A
31	Check & confirm all lights / LEDs / Switches / Horn working.	C,A	C,A	C,A	C,A	C,A	C,A	C,A

## PERIODIC MAINTENANCE & LUBRICATION CHART



Recommended frequency - Service interval & km									Remarks
8th	9th	10th	11th	12th	13th	14th	15th	16th	
34500 35000	39500 40000	44500 45000	49500 50000	54500 55000	59500 60000	64500 65000	69500 70000	74500 75000	
	CL,L				CL,L				Use recommended AP grease.
C,A	C,A	C,A	C,A	C,A	C,A	C,A	C,A	C,A	
	C,CL,L		C,CL,L		C,CL,L		C,CL,L		Replace if required. Use Limaplex HTX3 grease for lubrication
C,R	C,R	C,R	C,R	C,R	R	C,R	C,R	C,R	Replace oil and oil seal +Dust seal in pair at every 30 000 km
	L								Lubricate NRB at every 40,000 km Use AP grease.
C,R	C,R	R	C,R	C,R	R	C,R	C,R	R	Replace at every 15000 km
C,A,R	C,A,R	C,A,R	C,A,R	C,A,R	R	C,A,R	C,A,R	C,A,R	Check & Top up DOT4 brake Fluid in every service.
									Replace DOT 4 brake Fluid & Master / Caliper seals at every 30000 km
	C,T		C,T		C,T		C,T		
	C,R		C,R		C,R		C,R		Replace rear wheel rubber shock damper if required
C,A	C,A	C,A	C,A	C,A	C,A	C,A	C,A	C,A	Replace cables if operation found hard.
C,A	C,A	C,A	C,A	C,A	C,A	C,A	C,A	C,A	
C,A	C,A	C,A	C,A	C,A	C,A	C,A	C,A	C,A	Contact type switches if found sticky then use recommended WD40 spray

## PERIODIC MAINTENANCE & LUBRICATION CHART



Sr. No.	Activities / Check Points	Recommended frequency - Service interval & km						
		1st (Free)	2nd (Free)	3rd (Free)	4th	5th	6th	7th
		500 750	4500 5000	9500 10000	14500 15000	19500 20000	24500 25000	29500 30000
32	General lubrication – Clutch lever / Rear brake pedal	C,L	C,L	C,L	C,L	C,L	C,L	C,L
33	Front & Rear Tyre air pressure.	C,A	C,A	C,A	C,A	C,A	C,A	C,A
34	Mirror position & joint firmness.	C,A	C,A	C,A	C,A	C,A	C,A	C,A
35	All fasteners tightness, few are	C,T	C,T	C,T	C,T	C,T	C,T	C,T
	1. Front & rear axle							
	2. Swing arm axle							
	3. Engine foundation							
	4. Rider foot rest							
5. Pillion Stay								
36	Mobile USB port	C,R	C,R	C,R	C,R	C,R	C,R	C,R
37	Fuel tank water drain no blockage verification		C,CL	C,CL	C,CL	C,CL	C,CL	C,CL

**\*\*More frequent cleaning may be required while driving in dusty environment.**

**C : Check, A : Adjust, CL : Clean, R : Replace, T : Tighten, L : Lubricate**

**Note :** Periodic parts, Oil, Coolant, Filters, All types of greases, Cleaning agents, Cables, Wear & tear parts, Rubber 'O' rings / oil seals / pipes, Gaskets to be replaced as per Periodic Maintenance and Lubrication Chart are mandatory and the same are chargeable to customer.

## PERIODIC MAINTENANCE & LUBRICATION CHART



Recommended frequency - Service interval & km									Remarks
8th	9th	10th	11th	12th	13th	14th	15th	16th	
34500 ~ 35000	39500 ~ 40000	44500 ~ 45000	49500 ~ 50000	54500 ~ 55000	59500 ~ 60000	64500 ~ 65000	69500 ~ 70000	74500 ~ 75000	
C,L	C,L	C,L	C,L	C,L	C,L	C,L	C,L	C,L	Use recommended AP grease.
C,A	C,A	C,A	C,A	C,A	C,A	C,A	C,A	C,A	Use Tyre pressure gauge
C,A	C,A	C,A	C,A	C,A	C,A	C,A	C,A	C,A	
C,T	C,T	C,T	C,T	C,T	C,T	C,T	C,T	C,T	Use model wise torque values.
C,R	C,R	C,R	C,R	C,R	C,R	C,R	C,R	C,R	Charging OK to be checked at Engine start condition using LED USB light
C,CL	C,CL	C,CL	C,CL	C,CL	C,CL	C,CL	C,CL	C,CL	

Non-use maintenance is necessary if a vehicle remains off road for a longer duration (more than 15 days\*\*). The correct and careful non-use maintenance carried out before storing the vehicle will prevent the vehicle from rusting and from such other non-operational damages like fire hazards.

- Clean the entire vehicle thoroughly.
- Empty the fuel from the fuel tank and (if fuel is left in for a longer time, the fuel will break and gummy substance could clog the fuel system).
- Remove spark plug & put several drops of Engine oil into the cylinder. Crank engine over slowly a few times to coat cylinder wall with oil & install back spark plug.
- Set the vehicle on a box or a stand so that both wheels are raised off the ground.
- Spray oil on all unpainted metal surfaces to prevent rusting. Avoid getting oil on rubber parts or brake liners.
- Cover entire vehicle neatly. Make sure that storage area is well ventilated & free from any source of flames or spark.
- Fill 10% excess air pressure in both wheels.
- Do not apply oil on front brake disc, to prevent rusting. If the front brake disc rusts during storage, do not attempt to clean it with soap water. The rust will go off automatically during first few application of brake.

### **\*\*For Battery :**

- a. Remove battery and keep it on wooden plank, in properly ventilated area.
- b. Before taking the vehicle for use.
  - Get the battery recharged from the Authorised battery / BAL dealer.
  - Apply petroleum jelly on battery terminals.

### **Preparation for regular use after storage:**

- Follow daily safety checklist mentioned on page No.23.



## DELIVERY CERTIFICATE



FRAME NO.:

ENGINE NO.:

Sold on.: \_\_\_\_\_

Customer's Name Mr/Mrs/Miss : \_\_\_\_\_

Address: \_\_\_\_\_ Contact No.: \_\_\_\_\_

I have taken possession of motorcycle along with the following items.

- |                   |                         |               |               |
|-------------------|-------------------------|---------------|---------------|
| 1. Owner's Manual | 5. Standard Accessories |               |               |
| 2. 2 nos of key   | 6. Battery              | Make _____    | Sr. No. _____ |
| 3. Set of tools   | 7. Tyre                 | Fr Make _____ | Sr. No. _____ |
| 4. First Aid Kit  |                         | Rr Make _____ | Sr. No. _____ |

The Vehicle has been delivered to my satisfaction & I have understood all terms and conditions of warranty, service schedules & maintenance tips and shall abide by them.

Dealer Code :

Dealer Name :

Address :

Contact No. :

Customer's Signature (To be filled in by the dealer)

Important - Dealership should take customer sign & maintain the record of this (Delivery Certificate).

## WARRANTY : SCOPE & LIMIT



Bajaj Auto Limited provides the following warranty in respect of the “**Pulsar N125 BS VI**” motorcycle manufactured by us.

Every possible care and precaution has been taken to ensure quality in respect of the material & workmanship in the vehicles manufactured by us. Bajaj Auto Limited will repair or replace at their Authorised Workshops, free of charge, part or parts thereof as may be found, on examination, to have manufacturing defect within a period of 5 Year or 75,000 km., whichever is earlier from the date of sale subject to fulfillment of conditions stipulated in part A, B & C given here under

**Note : Warranty is applicable for only first owner of vehicle.**

### **Part A:**

Warranty claims in respect of such items like shock absorbers, speedometers etc. though claimed through us, are subject to acceptance of the respective manufacturers. In all such cases the decision of the respective manufacturer will be final and binding.

Proprietary parts like tyres, tubes and battery are warranted by their respective manufacturers and should be claimed on them directly by the customer. Bajaj Auto Limited shall not be Liable to replace them though their dealer, however Bajaj Dealers will provide full assistance in referring such claims with respective manufacturer.

Bajaj Auto Limited undertake no liability in the matter of consequential loss or damage caused due to the failure of the parts. Delay, if any, at the repairing workshop in carrying out repair to vehicle shall not be a ground for extending the warranty period, nor shall it give any right to the customer for claiming any compensation for damages.

Bajaj Auto Limited reserves the right either to repair or replace the defective parts.

Where a defective part can be replaced by part/s of alternative brand/s, which are normally used by Bajaj Auto Limited in the course of manufacture, Bajaj Auto Limited reserves the right to carry out the replacement by a part or parts of any such alternative brand/s.

This warranty and any claim arising there, is subject to Pune jurisdiction only.

### **Part B:**

No claim for exchange or repair can be considered unless the customer :

- a. Ensures that immediately upon detection of the defect, he approaches any nearest Authorised Bajaj Vehicle Dealers & Recommended Authorised Service Dealers with the concerned vehicle and enables him

to remove and despatch the part / parts attributing to the manufacturing defect to the Company.

- b. Produces the Owner's Manual, in original, to enable that dealer to verify the details. It must be expressly understood that claims forwarded directly to us by the owner / customer will not be entertained at all and such defective part/parts thus forwarded by them will lie at our factory at their own risk, and this warranty shall not be enforceable.

### **To avail benefits of warranty, following are mandatory**

1. Availing of Initial 3 Free Services without lapse.
2. Availing paid services at subsequent 5000 km. or 120 days from last service whichever is earlier without any lapse.
3. Availing of all services at the Authorised Vehicle Dealers & Recommended Authorised Service Dealers.
4. Usage of only recommended engine oil "**Bajaj 10000 10W40**" at specified frequency for drain interval of 10,000 km. & engine oil level top-up at 5000 km.
5. Replacing mandatory periodic parts such as air filter, oil filter etc. as per periodic maintenance schedule.

### **Part C :**

Further this warranty is NOT applicable to :

1. Normal maintenance operations like brake & clutch adjustments, cleaning of fuel system, engine tune-up or such other adjustments.
2. Parts subjected to normal wear & tear like Clutch Plates, Brake Shoes, Chain, Sprockets, Fork Oil Seal, Spark Plug, Control Cables, Brake Pads.
3. Replacement of bulbs & rubber components like grommets, 'O' rings, bellows as well as filters, packings, gaskets, fasteners etc.
4. Painted parts. Only blistering or peeling off of paint film are covered under warranty. Any defect arising out due to external damages or due to usage of protective covers /additional protective coatings adverse atmospheric conditions etc. are not allowed like under warranty.
5. All consumables like Engine oil, Fork oil, Brake Oil, Grease etc. are chargeable to customer.
6. Any defect arising due to above consumables not changed as per scheduled or if used other than the recommended one.
7. Never drive your bike through flooded roads or a flooded patch, as damages to the engine parts due to water entry is not covered under warranty.

## WARRANTY : SCOPE & LIMIT



8. All chrome plated parts are prone to rust or corrosion in coastal area or in acidic environment or due to neglected cleaning etc. However chrome film peeling is covered under warranty in general atmospheric conditions. Blue/ Yellow colouration of silencer near exhaust port is permissible and hence not covered under warranty.
9. Oxidation of unpainted / painted crankcase, cylinder block, cylinder head etc. in acidic environment or in a coastal area.
10. Parts of the vehicle that have been subjected to misuse, accident, negligent treatment OR which have been used in conjunction with parts & an equipment not manufactured or recommended for use by Bajaj Auto Limited, if found is the sole judgement of Bajaj Auto Limited, such use prematurely affects the performance and reliability of the vehicle.
11. Parts of the vehicle that have been altered and modified or replaced in unauthorized manner like use of wider tyres, loud silencers etc and which in the sole judgement of the Bajaj Auto Limited affects its performance and reliability.
12. **Vehicles which are not being serviced at Bajaj authorised dealers as per the service schedule described or which have not been operated or maintained in accordance with the instructions maintained in the Owner's Manual.**
13. Vehicles used for any competition or race and/or for attempting to set up any kind of record.
14. Any failure arising due to use of adulterated or bad quality fuel.  
Parts affected due to bad fuel quality are not covered Under warranty.
15. If additional electrical accessories such as - Remote, Bigger horn, Musical brake light etc. fitted on vehicle.
16. If the vehicle has been used for commercial purpose like Taxi or any other means of commercial transportation.

Bajaj Auto Limited reserves the right to make any changes in design or to add any improvements on the vehicle at any time without incurring any obligation to install the same on a vehicle previously supplied and sold. Also, the conditions of this warranty are subject to alteration without any notice.

This warranty is the entire written warranty given by Bajaj Auto Limited for **"Pulsar N125 BS VI"** motorcycle' and no other dealer or its or his agent or employee is authorised to extend or enlarge this warranty.

## BATTERY WARRANTY CARD



MAKE OF BATTERY : ..... MFG. CODE OF BATTERY :

BATTERY SR. NO.:  BATTERY CHARGING DATE : \_\_\_\_\_

TYPE OF BATTERY : \_\_\_\_\_ VEHICLE SALE DATE : \_\_\_\_\_

NAME OF OWNER AND ADDRESS : \_\_\_\_\_

TYPE OF VEHICLE : \_\_\_\_\_ REG. NO.: \_\_\_\_\_

FRAME NO.: \_\_\_\_\_ ENGINE NO.: \_\_\_\_\_

### SERVICE RECORD

Sr. No.	Date	Age Months	Voltage	Remarks	Dealer's Stamp & Signature	* Code
1						
2						
3						
4						
5						
6						

- \* Code For Remarks:**
- AE:** Electrical system needs attention.
  - IR:** Insufficient running of vehicle.
  - CB:** Cover broken.
  - BC:** Broken Container.
  - PM:** Poor maintenance.
  - BA:** Battery abused.

Note : Customer should insist that "Service Record" must be filled by respective authorised battery dealer as proof of specified maintenance for easy settlement of claim, if any.



USE ONLY BAJAJ GENUINE PARTS

*pulsar*  
N125



Always Use  
Bajaj Genuine  
High Performance  
Engine Oils

**4T**  
Premium  
Engine Oil

**BAJAJ**  
*10,000*

**10W 40**



**BAJAJ**  
*10,000*

**10W 40**



Top up  
bottle

**Long Drain Interval of 10,000 kms\***



Reduced Friction



Clean Engine Parts,  
Longer Engine Life



Smooth Clutch  
Control



\* Top up recommended at 5,000 kms

We are committed to provide the best of sales & service experience, however should you require any additional assistance, please call our Call centre on the number given below.



: 7219821111

**Call charges are as applicable**

**Call centre timings :- Monday to Sunday  
(09 : 00 am - 08 : 00 pm)**



Please download customer care app from '**Google play store**' and '**Apple store**' and book the vehicles for servicing and more on your phone.

E-mail : [customerservice@bajajauto.co.in](mailto:customerservice@bajajauto.co.in)

Web Site : [www.bajajauto.com](http://www.bajajauto.com)

CIN : L65993PN2007PLC130076