



pulsar
NS400



THE WORLD'S
FAVOURITE
INDIAN

Owner's Manual



FOREWORD



Welcome to the Pulsar family!

You are now the proud owner of the next generation **Pulsar NS400 BSVI, the biggest Pulsar ever!** India's No.1 sports bike. By No.1 we are talking about unparalleled performance, superior technology and incredible market leadership that Pulsar today enjoys. This makes the Pulsar you ride, unbeatable and unchallenged both on and off the road.

Before you ride out, please read this Owner's Manual carefully and familiarize yourself with the operating mechanism, controls and maintenance requirements of your Pulsar. This will ensure you a safe and trouble free ownership experience.

To keep your bike in perfect running condition and deliver consistent performance, we have specially programmed the periodic maintenance services which includes 3 Free and subsequent Paid services, as per the schedule contained in this booklet. We earnestly advise you to avail all these services at any of our Bajaj Dealers or Authorised Service Dealers (ASD), who are well equipped with all necessary facilities / genuine parts / oil and trained manpower to ensure the best care for your Pulsar. Your **Pulsar NS400 BSVI** comes with a warranty of **5 Years or 75,000 Km** whichever occurs earlier from the date of sale. For details please refer to "Warranty : Scope & Limits" given in this manual.

Should you require any additional information feel free to contact us on helpline numbers or e-mail us at: **customerservice@bajajauto.co.in** or visit the Bajaj Auto website www.bajajauto.com

To be a part of the Pulsarmania, visit <https://www.bajajauto.com/bikes/pulsar> and follow Pulsar on Instagram at **@mypulsarofficial**.

Rev up, shift gears and enjoy the Pulsar experience...

SERVICE DEPARTMENT
BAJAJ AUTO LIMITED

TABLE OF CONTENTS



Description

1. Technical Specifications.....	1
2. Identification Data	4
3. Location of Parts	5
4. Steering cum Ignition lock.....	6
5. Fuel Tank Cap.....	7
6. Instrument cluster Details	8
7. Bajaj Ride Connect.....	20
8. Control Switches	22
9. Mobile Charger & E20 Petrol.....	24
10. Antilock Braking System.....	25
11. Pillion Seat / Tool kit	26
12. Rider Seat / Battery	27
13. Fitment of Rider & Pillion seat.....	28
14. Daily Safety Checks	29
15. How to ride your Bike	30
16. Safe Riding Tips	34
17. Engine Oil	35
18. Tubeless Tyre & Tyre pressure.....	36
19. Battery.....	37
20. Engine Cooling system.....	38
21. Coolant.....	39
22. Periodic Maintenance Information	40
23. Brake Fluid	42

24. Vehicle Cleaning and Washing Care.....	43
25. Monsoon Care.....	44
26. Free Service Guidelines	45
27. Periodic Maintenance & Lubrication Chart.....	46
28. Non Use Maintenance	54
29. Delivery Certificate	55
30. Warranty : Scope & Limit	56
31. Battery Warranty Card	59

Safety and Warning information :

Warning :



This indicates that a potential hazard or injury to you or other persons & to the vehicle can happen if advice provided is not followed.

Caution :



This indicates that a potential hazard that could result in vehicle damage. Follow the Advice provided with the caution.

Notice:

The description and illustration in this booklet are not to be taken as binding on the manufacturers. The essential features of the type described and illustrated herein remaining unaltered. Bajaj Auto Limited reserves the right to carry out at any moment without being obliged to bring this booklet upto-date & to do modifications on the vehicle, parts or accessories as may be convenient and necessary.

TECHNICAL SPECIFICATIONS



Parameter	Pulsar NS400 BS VI
Engine	4 Stroke, Single Cylinder
Bore x Stroke	89 mm x 56.1 mm
Engine Displacement	349.13 cc
Compression Ratio	12.2 : 1
Idling Speed	1550 ± 150 rpm
Max. Net Power	29.86 kW (40.6 PS) at 9000 rpm
Max. Net Torque	33.2 Nm at 7500 rpm
Ignition System	DC
Fuel System	Fuel injection System
Spark Plug	1 Number
Spark Plug Gap	0.8 ~ 0.9 mm
Lubrication	Wet sump forced Lubrication
Transmission	6 speed constant mesh
Gear shifting Pattern	1 Down 5 Up
Engine Cooling	Liquid cooled
Starting Aid	Electric starter
Front & Rear Brake	Disc Brake

TECHNICAL SPECIFICATIONS



Parameter	Pulsar NS400 BS VI
Fuel Tank Capacity	
Full	12 L (No Reserve)
Dimensions	
Length	1990 mm
Width	846 mm
Height	1057 mm
Wheel base	1344 mm
Ground Clearance	165 mm
Front Tyre Size	110/70-ZR17 M/C 54W, Tubeless
Rear Tyre Size	150/60-ZR17 M/C 66W, Tubeless
Tyre Pressure	
Front	2.04 Kgf/cm ² (29 PSI)
Rear (Solo)	2.25 Kgf/cm ² (32 PSI)
Rear (with pillion)	2.25 Kgf/cm ² (32 PSI)
Electrical System	12 V DC
Battery	12 V 8Ah VRLA
Head Lamp	LED
Tail / Stop Lamp	LED

TECHNICAL SPECIFICATIONS



Parameter		Pulsar NS400 BS VI
	Position Lamp	LED
	Side Indicator Lamp	LED
	Rear No. Plate Lamp	LED
Instrument Cluster	Neutral Indicator	LED - Green
	Hi-Beam Indicator	LED - Blue.
	Speedometer Illumination	Reverse LCD - Color
	Fuel Level Indicator	Bar type - Display on digital console
	Malfunction Indicator	LED - Amber
	High Engine Temp. Indicator	LED - Red
	Low Oil Pr. Indicator	LED - Red
	Turn Signal Indicator	LED - Green
	Traction Control Indicator	LED - Amber
	MTC OFF	Display on digital console
	Side Stand Indicator	Display on digital console
	ABS Indicator	LED - Yellow
	Horn	12 V DC
	Vehicle Kerb Weight	176 kg
	Vehicle Gross Weight	324 kg

Note : • All dimensions are under UNLADEN condition. • Above information is subject to change without any notice.
 • This vehicle complies to BS VI standards. • AHO is government regulation.

IDENTIFICATION DATA



The Frame and Engine serial numbers are used to register the motorcycle. They are the unique alpha-numeric codes to

identify your particular vehicle from others of the same model and type.

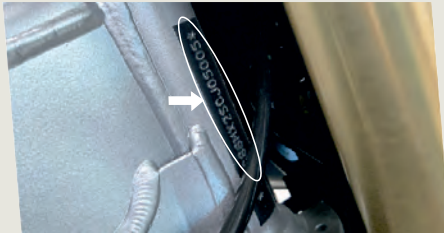

- ▶ **Frame Number Location**
On RH Side of Steering Tube
(Alpha-Numeric - 17 Digits)

Engine Number Location

On LH Side Crankcase Near Gear
Change Lever (Alpha-Numeric - 11 Digits)



LOCATION OF PARTS

pulsar
NS400

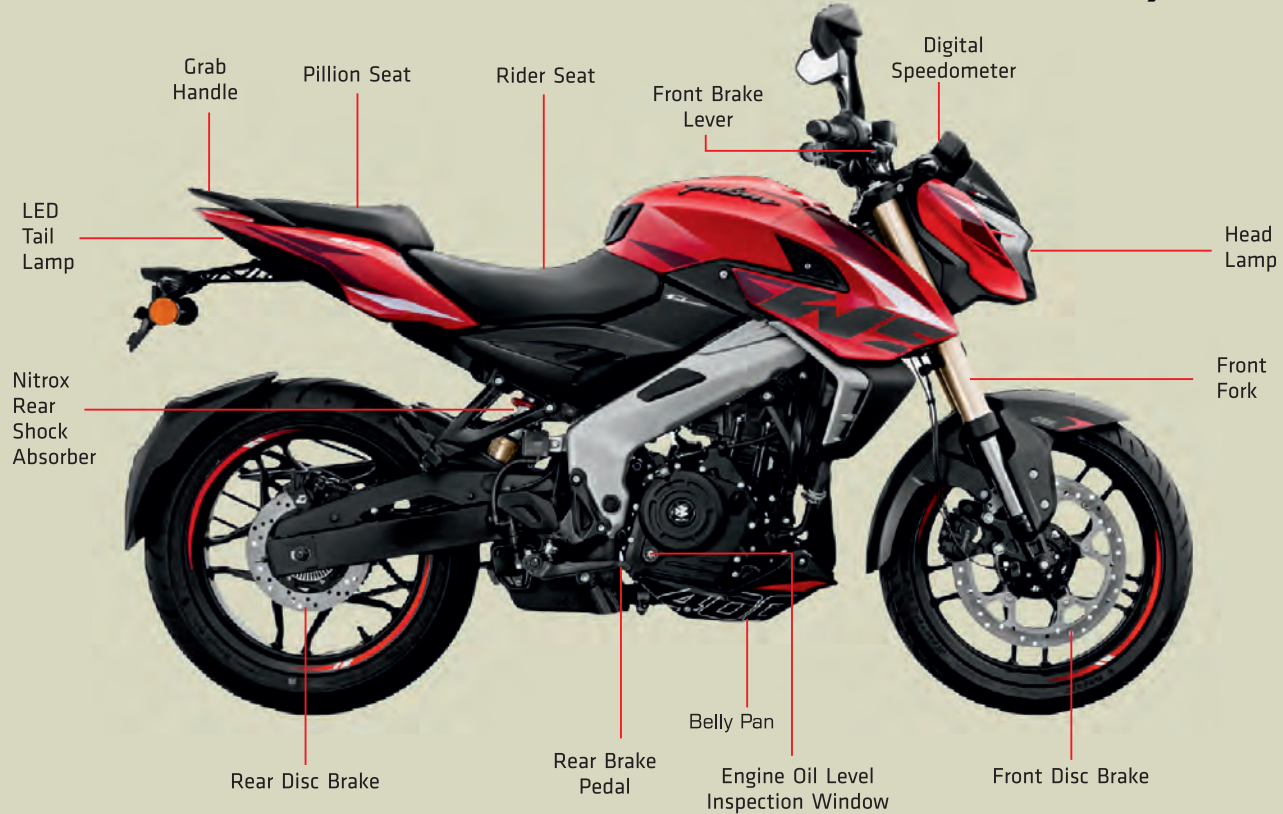

STEERING CUM IGNITION LOCK

pulsar
NS400

Steering cum Ignition Lock :

It has three positions.



- **LOCK:** Steering locked. Ignition OFF.
- ❓ **OFF:** Steering unlock. Ignition OFF.
- ❓ **ON:** Steering unlock. Ignition ON.

To Lock the Steering : To lock the steering, turn the handle bar to the left side. Turn the handle bar to the left or right. Push & Rotate the key to "LOCK" position & remove the key.

Steering locking on handle position left hand side only.

To Unlock the Steering : Insert the key in steering cum ignition lock. Push & Rotate it clockwise to "OFF" or "ON" position.

Key : A common key is used for 'Steering cum Ignition lock', 'Fuel tank cap' & 'Rear Seat'.

"Cranking ON and OFF duration" control –

- During Engine crank cycle cranking is allowed only for fixed duration and in between successive cranks (in case engine does not start) here is a cooling off period.
- Cranking on-off duration control feature to avoid battery discharge-
 - 1st Crank ON (5 sec) & Disable for 2 sec.
 - 2nd Crank ON (5 sec) & Disable for 2 sec.
 - 3rd Crank ON (5 sec) & Disable for 10 sec.

After a gap of 10 sec cranking cycle continues.

- **Starter disabled if side stand down** – With side stand down condition and vehicle in gear, Engine cranking is disabled through ECU.
- Headlight control on rpm – Headlamp will be turned ON only at Engine running condition.

FUEL TANK CAP

Pulsar
NS400



- There is no fuel cock.
- Always maintain minimum 3 Liter Petrol in fuel tank.
- Do not use adulterated fuel as it will result in rusting & clogging of Injector, Fuel pump module & catalytic Converter.

Fuel Tank Cap

- To open the fuel tank cap, open the flap, insert the key in the lock and turn it clockwise and lift fuel tank cap.
- To lock the 'Fuel tank cap' insert the key in the lock and turn it clockwise and press fuel tank cap. 'Click' sound ensures cap is fully locked.

Precaution : Don't attach metallic 'key chain' as it may damage paint of petrol tank cover.

⚠ Caution

- In case petrol is spilled out on petrol tank, it is to be immediately cleaned with clean soft cotton cloth to prevent permanent stain marks on petrol tank.



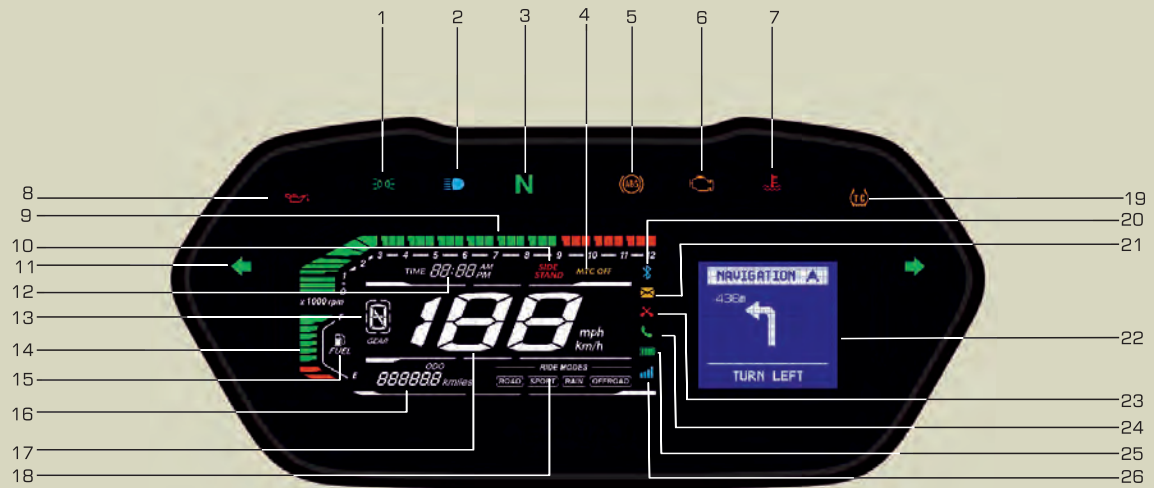



INSTRUMENT CLUSTER DETAILS



INSTRUMENT CLUSTER DETAILS



Speedometer display will work when Ignition switch is in 'ON' position and Kill switch in "ON" position.

- 1. Position lamp Indicator ():** It Indicates Position lamp indicator is ON.
- 2. High Beam Indicator ():** It glows when Headlight is ON & High beam is selected with engine running or Pass beam is selected.
- 3. Neutral Indicator ():** When the transmission is in Neutral, Neutral indicator will glow.
- 4. MTC OFF:** It gets displayed when traction control is deactivated. When traction control is activated MTC OFF will disappear from instrument cluster.
- 5. ABS Indicator ():** With Ignition switch ON the ABS indicator glows. When vehicle speed is more than 5 km/h the ABS indicator goes off, if this indicator glows while vehicle is running, it means there is problem in ABS.
- 6. Malfunction Indicator ():** It glows whenever any abnormality is noticed in functioning of FI system related components.
- 7. Coolant Temperature Indicator:** It glows when engine coolant temperature is more than 110°C.
- 8. Low Oil Pressure Indicator ():** It glows when engine oil pressure is low.
- 9. Tachometer Bar:** It shows engine speed in rpm. Tachometer bar blinks if rpm is greater than 9000.

10. Side Stand Indicator: It gets displayed when side stand is down.

Side Stand Condition	Gear position	Remark
Down	Engine in neutral gear position	Self-start / kick start possible
	Shifting gear from 'N' to 1st gear in engine start condition by pressing clutch lever	Engine will get cut off
Down	Engine in gear position	Engine will not start by self-start / kick start.

11. Turn Signal Indicator (): When Turn signal switch is pushed to Left or Right, Turn Signal Indicator - LH or RH will flash.

12. Digital Clock: It indicates time in HH:MM (AM/PM).

13. Gear Indication (): It will display gear position from 1 to 6. It will display **N** when vehicle is in neutral position.

14. Fuel Level Indicator: It shows available fuel in fuel tank.

15. Low Fuel Level Indicator: () It blinks in case of low fuel level (1 bar or less).

16. Odometer: The odometer shows the total distance that the vehicle has covered. Odometer cannot be reset to 'Zero'

17. Speedometer: Vehicle speed will be displayed in digital form in km/h.

INSTRUMENT CLUSTER DETAILS



18. Ride Modes: ABS & EMS ride modes namely Road, Sport, Rain and OFF-Road are provided with best optimized ABS intrusion suitable under each mode.

Ride Mode Selection is done in Multi Information Display.

- In Main menu, select Vehicle info by using up/ down buttons of control switch LH & upon selection, press Set button for less than 1sec to enter Vehicle info.
- Vehicle info section contains 3 sections:
 - 1. Ride Mode** - It shows all four ABS ride modes namely Road, Sport, Rain & OFF-Road
 - 2. MTC** - MTC avoids or limits the slipping of wheels on the roads or on slippery surfaces during the acceleration. MTC can be deactivated in sports & OFF-Road mode only.
 - 3. Sport Shift** : This feature allows to shift gear without pressing clutch lever.
 - 4. Warnings** - It displays warnings messages.



- Enter Ride mode by pressing Set button for less than 1sec on control switch LH.
- Upon entering Ride modes, now all four Ride modes are visible. Rider can toggle through the Ride modes using up / down buttons on control switch LH for selecting the desired Ride mode.
- Select the desired Ride mode & press Set button for less than 1sec. Desired Ride mode gets selected and a message is displayed "XXXX MODE ACTIVATED".



- Rider is required to do Zero throttle to change the desired mode
- In case throttle is not at Zero condition & rider tries to change the Ride mode, message is displayed "CLOSE THROTTLE".

INSTRUMENT CLUSTER DETAILS



MTC - MTC is used to activate or deactivate MTC function. MTC can be deactivated in Sport & OFF-Road mode only.



- Enter MTC by pressing Set button for less than 1 sec on control switch LH.
- Upon entering MTC, two options are visible:
- **1. ON** - It activates MTC, If deactivated in Sport & OFF-Road mode.
- **2. OFF** - It deactivates MTC in Sport & OFF-Road mode. For Deactivating MTC, Select OFF & Press Set button on control switch LH till "Release" message is displayed in instrument cluster. When MTC is deactivated, MTC OFF glows in instrument cluster.



- **Note:**
- MTC can only be deactivated in Sport & OFF-Road Mode only.
- IF tried to deactivate MTC in Road & Rain mode, message will appear in Multi info display "CHANGE RIDE MODE".
- Bike has a default mode which is set to "ROAD".
- If any system related error is present, only in that case default mode will be activated.



Ride Mode selection while vehicle running:

- Selection is accepted only in condition of Zero throttle.
- For OFFROAD mode selection vehicle speed should be less than 20 km/h.

INSTRUMENT CLUSTER DETAILS



Ride Modes:

A. Road Mode: Road mode is designed for everyday riding on typical paved roads.

- In this mode, engine performance is optimized for balanced power delivery, providing smooth acceleration and responsive throttle control.
- The ABS braking system is configured to deliver reliable braking performance under normal road conditions, with a focus on stability and control.

B. Sport Mode: Sport mode is geared towards spirited riding and performance-oriented enthusiasts.

- In Sport mode, the motorcycle's engine is tuned to deliver heightened throttle response, allowing for brisk acceleration and aggressive cornering.
- The ABS braking system in Sport mode is calibrated to provide maximum stopping power while still maintaining stability, allowing riders to push the limits with confidence.

C. Rain Mode: Rain mode is tailored for riding in wet or slippery conditions, where traction is significantly reduced.

- In Rain mode, the engine's power output is appropriately limited, with a gentler throttle response to prevent wheel spin and loss of control on slick surfaces.
- The ABS braking system is fine-tuned to modulate brake force more conservatively, minimizing the risk of wheel lock-up and skidding on wet roads.

D. Off Road Mode: Off-road mode is specially crafted for tackling rugged terrain and unpaved surfaces.

- In Off-road mode, the engine's power delivery is adjusted to offer better low-end torque and traction control, essential for navigating uneven trails and obstacles.
- The ABS braking system in Off-road mode is often optimized for off-road conditions, allowing for controlled braking on loose surfaces while preventing wheel lock-up and maintaining stability during descents.

19. Traction Control Indication (TC): Traction control system avoids or limits the slipping of wheels on the roads or on slippery surfaces during the acceleration. TC icon glows when Traction control is activated.

When vehicle speed is more than 5 km/h the Traction control indicator goes OFF, if this indicator glows while vehicle is running, it means there is a problem in Traction control system.

Traction control can be switched off in "SPORT" & "OFFROAD" Ride Mode.

20. Bluetooth icon on Instrument cluster: It displays status of your smartphone pairing with your vehicle.

When ignition key turned "ON" bluetooth icon will blink for 10 seconds. Post that bluetooth icon will disappear, but will be active in background for pairing with smartphone.

Bluetooth icon steady: Paired with smartphone.

INSTRUMENT CLUSTER DETAILS



21. Message Alert: If your smartphone is paired with the instrument cluster of your vehicle via bluetooth, then you will get all the message alert on the instrument cluster. Incoming message alert icon will blink for 6 seconds. Post 6 seconds, message alert icon will displayed steady "ON".

If ignition key is turned "OFF" and then "ON" text message indication will disappear until a new message is received.

22. Multi Information Display: It displays various information:



A. Vehicle Info :

a. Ride Modes : Four ABS & EMS Ride modes namely Road, Sport, Rain & OFF- Road are provided in this bike, Desired Ride mode can be selected by rider using this menu.

b. MTC (MTC ON / MTC OFF) : MTC is used to activate or deactivate MTC function. MTC can be deactivated in Sport & OFF-Road mode only.

c. Sport Shift : This feature allows to shift gear without pressing clutch lever. Sport shift is only available in Sport mode. When the rider changes the ride mode from Sport to any other mode, Sport shift will be turned OFF.

Incase Sport shift menu is accessed in Road, Rain or Off Road mode message will appear in Multi info display "CHANGE RIDE MODE TO SPORT".

Based on rider requirement, Sport shift feature can be deactivated or activated in Sport mode.

To access Sport shift feature during navigation long press SET button.

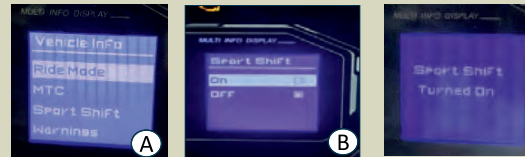

d. Warning Messages : It displays warnings messages.

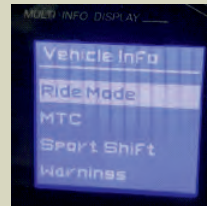

INSTRUMENT CLUSTER DETAILS



B. Connectivity :

a. **Bluetooth (ON / OFF)** : Using this menu rider can turn bluetooth ON & OFF.

PULSARXXXX : PULSARXXXX is the broadcasting name for bluetooth connectivity & Pairing of Bajaj Ride Connect App with instrument cluster.

b. **Music** : If rider smartphone is paired with the instrument cluster of the vehicle via bluetooth, Then rider will be able to do following action - Music volume up / down & pause, Play, Shift to next & previous track.



C. Trip & Bike :



a. Trip A : Parameters under Trip A

1. **Trip A** - It shows the total distance that the vehicle has travelled in Trip A mode. If Trip A is reset, Average fuel economy (AFE A) will reset.

2. **Trip A Average Speed** - It shows average speed of vehicle in Trip A mode.

3. **AFE A (Average Fuel Economy A)** -

This indicates average fuel economy in km/L in Trip A mode.

4. **Trip A Time** - It shows total time that the vehicle has travelled in Trip A mode.



b. Trip B : Parameters under Trip B

1. **Trip B** - It shows the total distance that the vehicle has travelled in Trip B mode. If Trip B is reset, Average fuel economy (AFE B) will reset.

2. **Trip B Average Speed** - It shows average speed of vehicle in Trip B mode.

3. **AFE B (Average Fuel Economy B)** - This indicates average fuel economy in km/L in Trip B mode.

4. **Trip B Time** - It shows total time that the vehicle has travelled in Trip B mode.

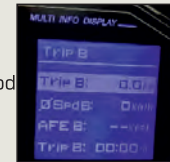

INSTRUMENT CLUSTER DETAILS



Trip Meter Reset :

- Select Trip A/ Trip B and Press Set button for less than 1 sec on control switch LH.
- New option will come as “Keep/ Reset”, Select reset and press Set button on control switch LH for less than 1sec if Trip A or Trip B reading is to be reset.

c. Bike Info :

1. Battery voltage - It displays voltage of battery fitted in vehicle.

2. DTE (Distance To Empty) - It indicates the estimated distance that the vehicle can travel under current fuel economy and fuel level condition. DTE calculation is independent of Trip & based on AFE for distance covered for last 25 km. Max count of DTE is 990 km. Instrument cluster will display values in multiple of 10.

3. Service -

a. Distance To Service - It displays the distance left for next periodic service.

b. Instrument cluster details - It displays instrument cluster firmware and bluetooth version details.

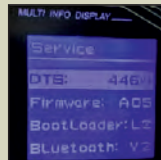

D. Lap Timer : Lap Timer calculates & stores multiple lap timings until reset. It also displays best lap timing among all laps.



- To start lap timer, press Set button on control switch LH for less than 1 second. To continue for lap 2 & so on, Press Set button on control switch LH for less than 1 second.
- Lap timer can store a total time of 9 hr 59 min 59 sec 99 msec
- When rider leave the lap timer menu without stopping or pausing the lap timer, The lap time continues to run in the background.
- If we pause, The lap timer will pause as well, and even if we exit the lap timer menu, It will not be deleted. Lap timer will reset after every ignition cycle.

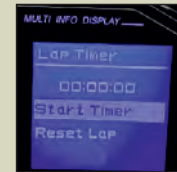

INSTRUMENT CLUSTER DETAILS



- To reset lap timer, Press "Set" button on control switch LH for less than 1 second and select option reset.

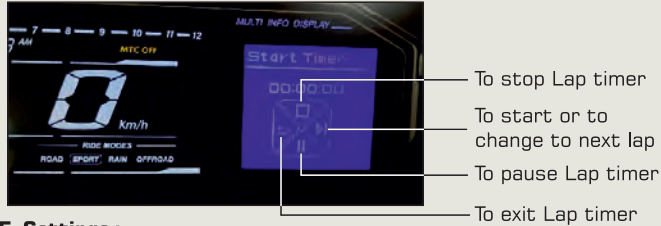

E. Settings :



- a. Favorite :** There are 11 favorites in menu from which 4 can be selected by user to be displayed in home screen.
- b. Quick Select :** There are 11 Quick Select in menu from which 2 can be selected by user for Up and Down button.

- c. Date & Clock :** Enter Date & Clock setting by selecting & pressing Set button on control switch LH for less than 1 second. It has 2 settings:
- Clock setting -** Digital clock indicates time in HH & MM separated by colon ':' It is 12 hour clock.

Select Clock Setting and press Set button for less than 1 sec.	HH digits starts blinking.
Press up/ down button for less than 1 sec.	Hour digits will increase/ decrease.
Press Set button for less than 1 sec.	HH value will be stored while MM starts blinking.
Press up/ down button for less than 1 sec.	Minute digits will increase.
Press Set button for less than 1 sec.	Minutes value will be stored. AM & PM starts blinking
Press up/ down button for 1 sec.	Select AM/ PM.
Press Set button for less than 1 sec.	AM/ PM value will be stored. HH digits starts blinking. Press return button to come out of clock setting.
Clock set mode is selected & no ending is carried out.	Auto exit without saving set value. If engine / vehicle rpm is given then system will exit from clock set mode without saving set value.

INSTRUMENT CLUSTER DETAILS



- **Date setting** - Date is displayed in DD-MM-YYYY.

Select Date Setting and press Set button for less than 1 sec.	DD digits starts blinking.
Press up/ down button for less than 1 sec.	Date digits will increase/ decrease.
Press Set button for less than 1 sec.	DD value will be stored while MM starts blinking.
Press up/ down button for less than 1 sec.	Month digits will increase/ decrease
Press Set button for less than 1 sec.	Month value will be stored. Year values starts blinking
Press up/ down button for 1 sec.	Year digits will increase/ decrease.
Press Set button for less than 1 sec.	Year value will be stored. DD digits starts blinking. Press return button to come out of Date setting.
Date set mode is selected & no ending is carried out.	Auto exit without saving set value. If engine / vehicle rpm is given then system will exit from date set mode without saving set value.

- d. **Brightness** : Instrument cluster adjust brightness intensity based on headlamp switch position.

●	: Headlamp OFF, DRL 'ON' with High Intensity Instrument cluster brightness intensity "HIGH"
☀	: Headlamp ON, DRL 'ON' with Low Intensity Instrument cluster brightness intensity "LOW"

Instrument cluster brightness can be further adjusted by rider as per requirement from multi information display menu as per options given below.

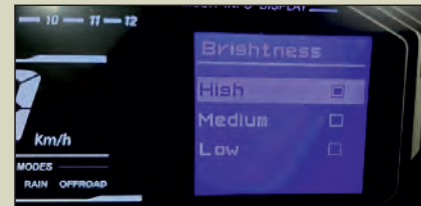
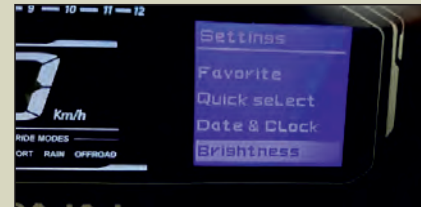

INSTRUMENT CLUSTER DETAILS



Turn by Turn Navigation: The Dot matrix is used for Turn by Turn navigation.

By default navigation is "OFF". To use navigation, your smartphone is to be paired with the instrument cluster of your vehicle via bluetooth.

Default: OFF

Navigation can be turned "ON" from "Bajaj Ride Connect" App by entering destination. Based on turn, it will show turn details and navigation information.



Dot matrix Multi Information display will show following information's while using TBT navigation:

- "NO GPS" when smartphone GPS signal is not available.
- "REROUTING" when application is rerouting navigation.
- "DESTINATION" "REACHED" in when vehicle reached the desired location.
- Display will toggle between "ETA" (Estimated time of arrival) and "ETD" (Estimated travel distance).
- "TURN-XXXX" if any turn is ahead, "XXXX" if vehicle needs to go on straight and "UTURN-XXXX" if a uturn is ahead.
- **Note:** Map will be available for 7 years only.

23. Missed Call Alert: If your smartphone is paired with the instrument cluster of the vehicle via bluetooth, then you will get the missed call alerts on the instrument cluster.

24. Incoming Call Alert: This symbol will become active and displayed blinking when there is incoming call and displayed steady "ON" only when call is received (If your smartphone is paired with the instrument cluster of the vehicle via bluetooth). While receiving a call, caller's name/ mobile number will be displayed at multi-information display area. Call accept/reject with the help of Call button on control switch LH

25. Smartphone Battery level: If your smartphone is paired with the instrument cluster of the vehicle via bluetooth, then it will display battery level of your smartphone on instrument cluster.

26. Smartphone Network Range: It will display network of your smartphone on instrument cluster of your vehicle when connected via bluetooth.

INSTRUMENT CLUSTER DETAILS



Note :

After switching 'ON' the ignition switch, the following indications will remain 'ON' till engine is started.

- Malfunction Indicator
- Low Oil Pressure Indicator
- ABS Indicator
- Coolant Temperature Indicator
- Traction control icon

Instructions :

Incase Coolant temperature indicator, Malfunction indicator, Low oil pressure indicator, ABS indicator gets ON during vehicle running, bring the vehicle nearest BAL authorised workshop for inspection/repair.

BAJAJ RIDE CONNECT



Bajaj Ride Connect Application:

“Bajaj Ride Connect” Application is based on bluetooth connectivity with the instrument cluster. This app offers a range of features, including vehicle management, service booking, document storage and more. With seamless bluetooth connectivity to Pulsar, the app ensures a personalized and convenient riding experience for every register user.

Key features of the application:

Bluetooth: once connected to the vehicle through the application user can access below bluetooth features:

- Call Accept/ reject with the help of Call button on control switch LH.
- Smartphone battery level.
- Smartphone network range.
- Missed call.
- Message alert.

Service:

- Book service appointment for relevant service type.
- Locate nearby BAL workshop location.

Document storage: Important vehicle related documents, such as insurance paper and registration certificates, can be securely stored within the app, providing easy access whenever needed.

 **Caution:** Document storage works as a digital wallet and is only for storage purpose.

Reminders: Users can set reminder for vehicle maintenance, service schedules, insurance renewals and other important tasks.

Trip with Turn by Turn Navigation: The app provides comprehensive navigation services with voice guidance, allowing users to set multiple stops and reach their destinations conveniently. It allow users to record their trips, capturing valuable data such as distance, duration and route. Additionally, users can share their exciting journeys with friends and family.



BAJAJ RIDE CONNECT



Application download:

Bajaj Ride Connect application is available in the Google play store (for android) or Apple store (for iOS).

- Download the “Bajaj Ride Connect” App from Google play store/ Apple store.
- Click on “Sign up” to register in the App with your registered mobile number.
- Enter your personal details (first & last name).
- Enter VIN of your vehicle (VIN can also be scanned).
- Click on “Sign up”
- Enter OTP.
- Login in App
- “Bajaj Ride Connect” App is ready to work.

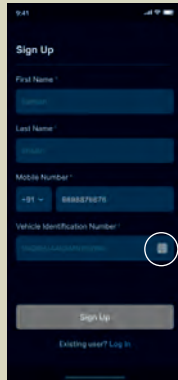
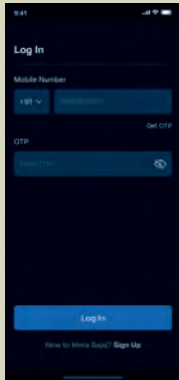

Bluetooth connectivity:

Your vehicle is equipped with bluetooth connectivity feature by which you can pair your smartphone with instrument cluster of your Pulsar vehicle through “Bajaj ride connect” application.

- Turn the ignition switch and kill switch “ON”.
- Login “Bajaj ride connect” application on your smartphone.
- For first time pairing, allow the application to access:
 - a. Device's location if GPS is not enabled in your device.
 - b. Access your phone called logs.
 - c. Send and view messages.
 - d. Notification's

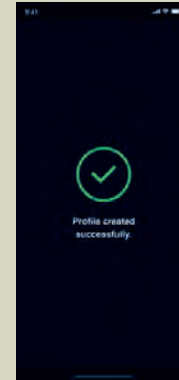
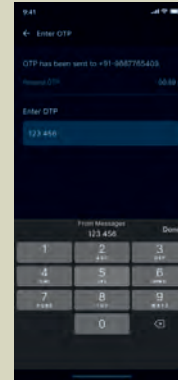

CONTROL SWITCH - LH

pulsar
NS400

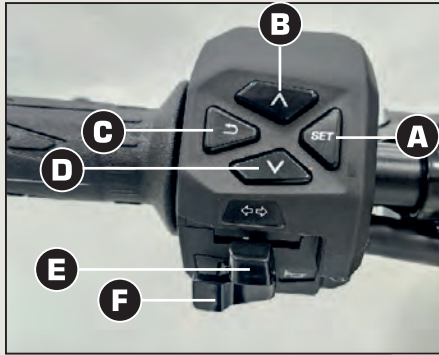

- A. Set Button:** Set button is used for :
- Call Accept: Press Set button for less than 1 sec.
 - Menu Selection: Press Set button for less than 1 sec.
- B. Upward Toggle switch:** It is used to toggle towards upwards option in menu.
- C. Exit Button:** Exit button is used for:
- Call Reject: Press Exit button for less than 1 sec.
 - Menu Exit: Press Exit button for less than 1 sec.
- D. Downward Toggle switch:** It is used to toggle towards downwards option in menu.

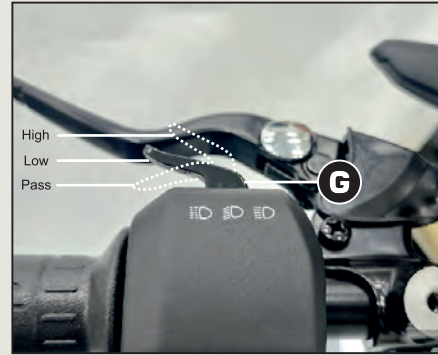

- E. Turn Signal Switch:** When the turn signal knob is turned to Left (←) or Right (→) respective indicator will start blinking, to stop blinking push the knob in & release.
- F. Horn Button (📢):** Press button for sounding horn.
- G Pass Switch:** Press the switch to put 'ON' Hi Beam/ Low Beam/ Pass light.
It is used to give signal to vehicles coming from opposite side while overtaking.

When headlight is ON, High or Low beam can be selected with this switch. Hi beam indicator light located on Speedo console will light up when high beam is selected.

☰: High Beam

☷: Low beam

CONTROL SWITCH - RH

pulsar
NS400



H. Hazard Switch: When hazard switch is pressed all 4 indicators will blink. Rider must only use vehicle hazard light when his vehicle is stopped in a hazardous position or rider is driving in hazardous conditions, such as rain or fog.

I. Engine Kill Switch & Starter Button: It is a combi-switch used for switching ON & OFF the engine and to start the vehicle.

It is recommended to start the engine with the transmission in neutral.

Vehicle in gear - Press clutch lever & operate starter button to start the engine.

- ⊗ : Engine OFF
- ⊙ : Engine ON
- ⊚ : Engine Start

J. Light Switch: It has 2 positions. When ignition switch is 'ON' & Engine is 'ON', lighting system will work as per given table.

- : Tail lamp will get 'ON'. DRL 'ON' (High Intensity)
- ☀ : Head lamp, Tail lamp, Number Plate lamp & Position lamp will get 'ON'. DRL remains 'ON' (Low intensity)

Day Time Running Light Feature:

- Day Time Running light is provided inside headlamp.
- Day Time running light gets 'ON' (High intensity) when ignition switch turned to 'ON' position.
- After headlight is turned to 'ON' position with **engine running** intensity of DRL LED's will get reduced.

Ignition Switch	Light Switch	DRL	Head Light
ON	OFF	ON High Intensity	OFF
ON	ON	ON Low Intensity	ON

Mobile Charger & E20 Petrol

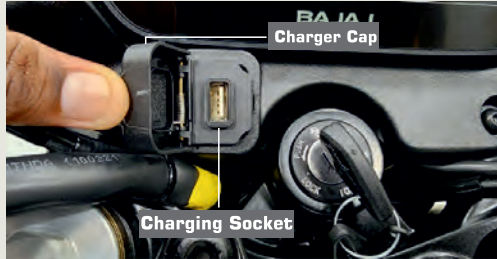

- Mobile charging socket has been provided on instrument cluster flap.
- The charger socket has been provided with cap to protect charger socket from dust & water entry during washing / during rain.
- Always ensure charger cap is firmly fitted on socket when charger socket is not in use.
- The mobile charger will supply output voltage only in engine running condition.
- Customer to use suitable USB cable for mobile charging.



E20 :

- This vehicle is compatible for “E20” Petrol i.e. Petrol blended with 20% Ethanol. E20 sticker affixed on fuel tank cap.
- In this vehicle ‘E10’ Petrol (existing) i.e. Petrol blended with 10% Ethanol also can be filled.



Caution:

Do not use mobile phone while driving. Momentary lapse in concentration might result in an accident.

ANTILOCK BRAKING SYSTEM (ABS)



ABS System

- Dual Channel ABS System is fitted in Pulsar NS 400 BSVI vehicles .
- Dual channel ABS means ABS is fitted on front & rear wheels.
- Always maintain a safe distance between you and objects ahead. Vehicle speeds should always be reduced during extreme road conditions. The braking distance for motorcycle equipped with an anti-lock braking system may be longer than for those without it on rough road conditions. During these conditions the vehicle should be driven at reduced speeds
- When you apply Front brake / Rear brake by pressing Front brake lever / Rear brake pedal under conditions which may lock the wheels, you feel a corresponding sensation (pulsation) in Front brake lever/ Rear brake pedal. (as applicable to model) This is normal and it means ABS is active.
- ABS technology requires the rider to brake appropriately to ensure safer braking specially under acute conditions.
- Also it is recommended to use both front and rear brakes simultaneously.
- Always slow down when cornering. The anti-lock brake system cannot prevent accidents resulting from excessive speeds.
- Never drive by disconnecting wheel speedometer cable.

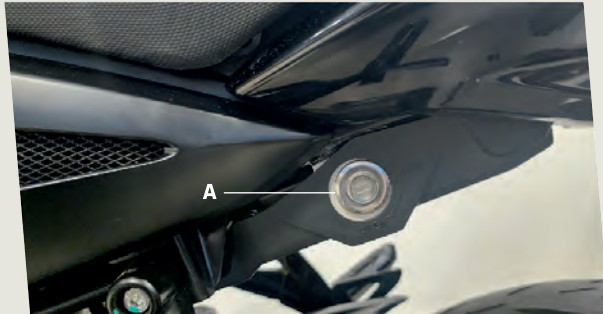

Removal of Pillion Seat

- Insert Key into lock (A)
- Turn the key clock wise.
- Lift front end of 'Rear seat'
- Pull 'Pillion seat' toward front side.
- Take out 'Pillion seat'.

Tool Kit Location

- It is located below the 'Rear seat'.
- 2 rubber straps are provided to hold the tool kit.



CAUTION : Always fit rubber strap for locking tool kit.



First Aid Kit Location

- It is kept inside seat cowl RH side.

RIDER SEAT / BATTERY

Pulsar
NS400

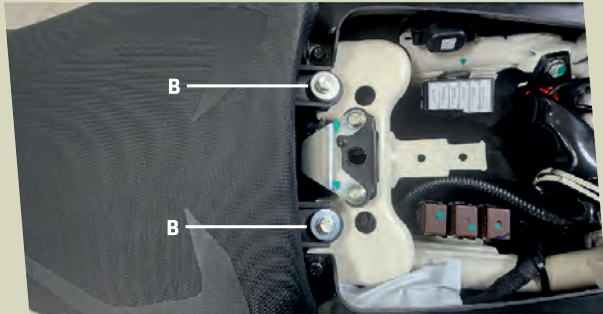

Removal of Rider Seat

- First remove 'Pillion seat'.
- Remove 'Rider seat' mounting bolts (B).
- Pull backward rear end of 'Rider seat'.
- Take out 'Rider seat'.

Battery

- It is located below 'Rider seat'.

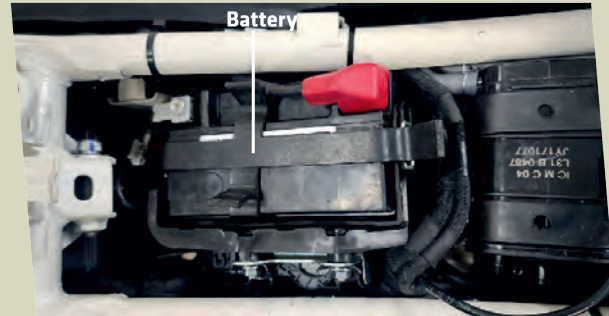

FITMENT OF RIDER & PILLION SEAT

pulsar
NS400

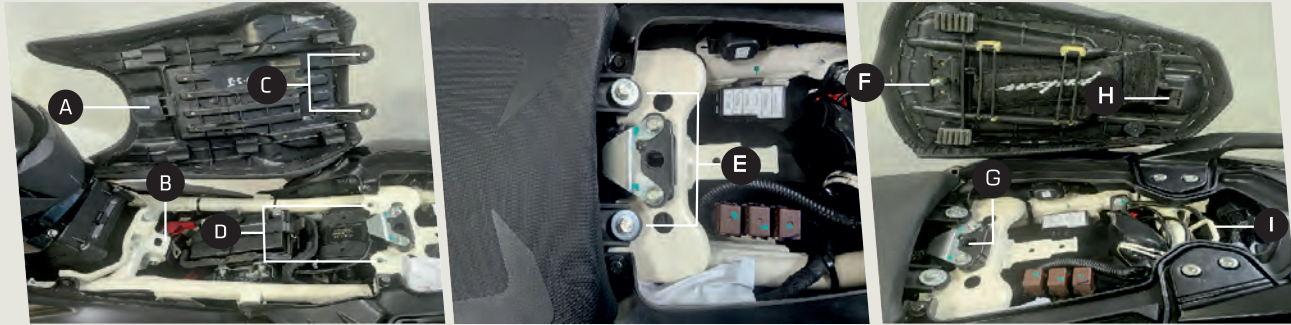

Fitment of 'Rider Seat'

- Match the bracket of 'Rider seat' (A) with slot (B).
- Push 'Rider seat' toward petrol tank.
- Match 'Rider seat' rear brackets (C) with the holes (D) provided on chassis.
- Tighten the bolts (E).

Fitment of 'Pillion Seat'

- First make sure 'Rider seat' is fitted properly.
- Ensure 'Tool kit' is located properly.
- Place 'Pillion seat' on fitment location.
- Match the bracket of 'Pillion seat' (H) with Hook (I).
- Insert lock rod (F) of seat into hook (G).
- Press front portion of seat.

DAILY SAFETY CHECKS



Before riding motorcycle be sure to check following items please give proper importance to these checks and perform all of them before riding motorcycle.

If any irregularities are found during these checks, refer to the Maintenance chapter & see your dealer for the action required to return the motorcycle to a safe operating condition.

⚠ Warning: Failure to perform these checks every day before you ride may result in serious damage or severe accident.

- Enough **fuel level** for planned distance of journey. No fuel leakage in fuel lines.
- **Engine oil** level (between upper and lower level mark)
- **Brake fluid** level above MIN mark provided on reservoir, applicable to disc brake vehicle.
- **Drive Chain** slack of 20~30 mm adequately lubricated.
- Function of all **lights & horn**
- **Clutch lever** play - 3 to 5 mm
- Check **Coolant level** between MIN and MAX mark in coolant reservoir tank.
- Smooth **steering movement** without restriction.
- **side stand** return to it's fully up position.
- Correct **inflation pressure** in both tyres. Adequate tyre tread depth - no cracks / cuts.
- Correct **rear viewing** span adjustment of mirror.
- Cleaning cloth not to be kept in vicinity of high temperature zone e.g. Radiator, engine, silencer assy, starter motor etc.
- Cleaning cloth to be strapped along with tool kit under rear seat assy.

HOW TO RIDE YOUR BIKE



1. Starting The Engine:

- Ensure minimum 3 liters petrol is available in fuel tank.
- Turn ignition switch key to '🔑' position.
- Put kill switch in '🔌' position.
- Confirm that transmission is in neutral/ press the clutch lever if transmission is in gear.
- Keep throttle closed & press starter button,
- Release starter button as soon as engine starts.

“Cranking ON and OFF duration” control –

Cranking ON-OFF duration control feature to avoid battery discharge-

- 1st Crank ON (5 sec) & Disable for 2 sec.
- 2nd Crank ON (5 sec) & Disable for 2 sec.
- 3rd Crank ON (5 sec) & Disable for 10 sec. After a gap of 10 sec cranking cycle continues.

Note

- The motorcycle is equipped with a clutch switch. This switch facilitates engine starting in neutral and gear position.

Gear Position	Clutch lever position
Neutral	Released
Gear	Fully pressed

- Incase of battery discharged condition please bring the vehicle to Bajaj Authorized workshop for repairs.

30

2. Shifting Gears:

- Close throttle and press the clutch lever fully.
- Shift into next higher or lower gear.
- Open the throttle and release the clutch lever slowly and simultaneously.



Gear shifting Lever

Gear shifting pattern

3. Moving Off:

- Check that side stand is up.
- Press the clutch lever.
- Shift into 1st gear.
- Open the throttle and release the clutch lever slowly and simultaneously.
- As the clutch starts to engage, open the throttle a little more, giving the engine just enough rpm to keep it from stalling.

Recommended Speed for Shifting Down

From 6th to 5th Gear	69 km/h
From 5th to 4th Gear	58 km/h
From 4th to 3th Gear	47 km/h
From 3th to 2th Gear	36 km/h
From 2th to 1th Gear	22 km/h

Warning

When shifting down to lower gear, do not shift at such high speed that engine rpm jumps excessively. This may cause engine damage, & rear wheel may skid. Downshifting should be done at recommended speeds as shown in table above.

4. Braking:

- Close the throttle completely, leaving the clutch engaged (except where shifting gears) so that the engine braking will help slow down the motorcycle.
- Shift down one gear at a time so that you are in Neutral when you come to a complete stop.
- When stopping, always apply both brakes at the same time.

5. Stopping the Vehicle :

- Close the throttle completely.
- Shift the transmission into neutral.
- Bring the vehicle to complete stop.
- Turn the ignition switch off.

6. Parking Using Side Stand:

- Support the motorcycle on a firm level surface with the side stand.
- Lock the steering on LHS.

 **Caution:** Do not park on a soft or steeply inclined surface or the motorcycle may fall over.

7. Running IN

Proper running-in is importance for the better life & trouble free performance of the vehicle.

- During first 2000 kms running-in period do not exceed following speed limits.

Kms	1st	2nd	3rd	4th	5th	6th
0- 1000	10	20	30	40	50	60
1000-2000	20	30	40	50	60	70

- Always keep speed below the limits given in table.
- Do not REV the engine excessively.
- Do not start moving or REV the engine immediately after starting. Run the engine for a minute at idle speed to give the oil chance to work up into the engine.

CAUTION

Always ensure side stand is UP while starting off.

Starter will be disabled if side stand down – With side stand down condition and vehicle in gear, Engine cranking is disabled through ECU & 'side stand down' Indication will be displayed in speedometer.

- Do Not REV engine in standstill condition.
- This vehicle has new 'Assist & Slipper' (A & S) clutch. Due to this, very little force is required for clutch lever operation. You won't feel jerks while sudden downshifting. Slight pulsation is felt at clutch lever. This is normal & indicates "A & S" clutch is working well.
- If engine coolant temperature crosses 110°C, coolant temperature high' alarm message will be displayed on primary speedometer indicating engine is overheated. **If vehicle is further driven in such a condition coolant temperature will increase up to 115°C & ECU will not allow engine to run above 4500 rpm.**
- Always maintain engine oil / coolant level between MIN & MAX mark at vehicle upright position on level surface.

HOW TO RIDE YOUR BIKE



Ensure following maintenance points to get optimum performance from your bike.

Fuel	Always maintain minimum 3 L Petrol in fuel tank.
Spark Plugs	Inspect and clean spark plugs. Adjust electrode gap. Replace spark plugs as per P.M. Chart.
Air Filter	Replace as per Periodic Maintenance Chart.
Engine Oil	Check engine oil level. Always use recommended grade and quantity.
Brakes	Ensure that the brakes are not dragging / binding.
Clutch	Ensure correct clutch lever play.
Tyre Air Pressure	Always maintain recommended tyre pressure.
Brake Fluid	Always maintain brake fluid level above minimum mark. Ensure no leakage of brake fluid in brake system.
Coolant	Always maintain coolant level between minimum & maximum mark. Ensure no leakage of coolant in cooling system.

Fuel Saving Tips :

A well maintained vehicle and good driving can contribute a lot to the saving of petrol. Following are a few simple fuel saving tips.

- Ride smoothly and steadily at an optimum driving speed to get best mileage.
- Avoid harsh braking.
- Change the gear judiciously according to the speed and load requirement.
- Don't overload the vehicle above the specified payload.
- Use the accelerator judiciously.
- Cut off the engine if you want to stop for more than two minutes.

How to check mileage (Fuel efficiency)

Best way to calculate mileage is by following the full tank to full tank method.

- Fill way tank full up to small mouth (brim).
- Run the bike for say 100 km.
- Fill the tank full again in same fuel filling station, probably with same fuel dispenser.
- Divide kilometer run / fuel quantity filled.

SAFE RIDING TIPS



- Always wear Helmet while driving or riding. Your helmet should conform to Indian standards.
- Read thoroughly the instructions given in this manual and follow them carefully.
- Avoid unnecessary accessories for the safety of both rider and other motorists.
- Get familiar and follow traffic rules & regulations in your states as well as general traffic signs.
- Familiarise yourself well with starting, acceleration and braking of the vehicle.
- When applying the brakes, use both front & rear brakes simultaneously. Applying only one brake may cause the vehicle to lose control.
- Riding at proper speed, avoiding unnecessary acceleration and braking are important for safety, low fuel consumption and longer life of the vehicle.
- During monsoon, drive vehicle more cautiously. Remember vehicle skid more easily during light showers.
- Keep both hands firmly on handle bar & both feet securely on rider footrest. Do not take away both hands & / or feet from resting area as this is very unsafe.

- Do not use mobile phones while riding as it could lead to fatal accident.
- It is suggested to customer to take appropriate care in area of heavy monsoon or high rainfall area. The appropriate surface preventive coat to avoid rusting / poor surface finish on account of adverse atmospheric conditions.
- Always carry vehicle registration & insurance papers, and a valid driving licence with you.

General Maintenance Tips :

- Vehicle cleaning to be done with soft & clean wet cloth to avoid scratches on painted parts.
- Clean & lubricate all the important parts as detailed in a periodic maintenance chart.
- Do not apply direct water jet on painted, electrical / electronic parts.
- Do not obstruct engine cooling by adding mud protection sheet from front
- Drive cautiously. Start early & reach your destination safely.
- Avoid driving on loose sand or stones where vehicle is likely to skid.
- Properly wrap-up loose clothes while driving or riding to avoid entangling in wheel or other objects on road.
- Always concentrate on riding for safety.

ENGINE OIL

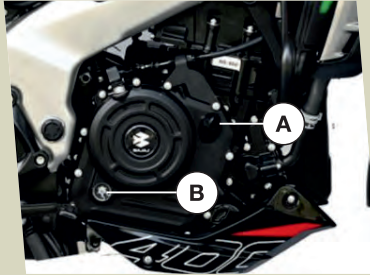

A : Oil Filler Cap
B : Oil Level Gauge

Engine oil level checking:

- Check engine oil level every day. park vehicle perpendicular to the ground on level surface.
- Check oil level through oil level gauge 'B'.
- Always maintain engine oil level between upper and lower mark provided on Cover RH. Top up with specified grade of oil if the oil level is below lower level mark.

Engine oil capacity:

- Refill at servicing: 1700 ml.
- During engine overhaul: 1950 ml.

Recommended Engine Oil:

Always insist on Bajaj Engine Oil for optimum engine performance and warranty benefits. It is a specially formulated oil for Bajaj vehicle engines.

Model	Recommended Engine oil
Pulsar NS400	Bajaj SAE 10W50, JASO MA2 API SN Fully Synthetic, BS6 Compliant

- **Engine oil replacement frequency** : 1st service & then every 10,000 km.
- **Engine oil level top-up frequency** : Every 5000 km.
- **For all BS VI Vehicles, above BS VI compliant engine oil is to be used only. Use of BS 6 engine oil will give prolonged life of catalytic convertor.**

Caution:

- It is most importance to adhere to recommended grade & frequency of oil change for the purpose of long life of critical engine components. For details refer periodic maintenance chart.
- Do not reuse drained oil.

TUBELESS TYRE & TYRE PRESSURE



Tubeless Tyre :

The main advantage of tubeless tyres is in case of puncture the rate of air leak is very slow, hence customer can easily drive the vehicle upto nearest puncture repair shop for removing puncture.



Note:

Incase the motorcycle is fitted with imported tyres compliance to respective Indian standard & central motor vehicle rules has been ensured.

Tyre puncture:

- Visit nearest known tubeless tyre repair shop to remove puncture.
- Remove puncture by filler or plug method only.
- Do not use patch method to remove puncture of tubeless tyre.

⚠ Caution: Tubeless tyres are fitted in this motorcycle. The walls of the tyres in contact with the wheel rim should not be damaged in any way during fitment / removal of tyre. The tyre side wall in contact with wheel rim seals air.

Tyre Pressure:

Keep recommended tyre pressure (as per Technical specifications) to increase life of the tyre & for better fuel consumption.

- Tyre warranty is settled by tyre manufacturer.
- Decision is taken based on tyre wear and running of vehicle.
- BAL settles tyre warranty for only imported tyres.

BATTERY



Battery: 12V - 8 Ah VRLA

- Battery is located below Rider seat.

Battery Features:

- No topping - up is required.
- Reduced self discharge, Enhance safety.
- No vent tube open to atmosphere hence no discharge of electrolyte through vent tube.

⚠ caution:

Do not drive / run vehicle in battery disconnected condition. It may lead to damage of electrical / electronic components.

- Environment care must be taken to dispose off the used battery.
- It is always recommended to hand over the same to the Authorised battery / BAL dealer for proper disposal of the same.
- Warranty on battery is 18 months from the date of purchase of vehicle.

How to keep battery healthy?

- Switch 'Off' ignition when engine is not running.
- get battery checked / Charged during periodic services.
- Do not add extra electrical accessories such as - Remote, Bigger Horn, Musical brake light etc. This will reduce life of battery & may damage ECU.
- Disconnect battery +ve & -ve wires if vehicle is to be stored for more than 2 weeks. This avoids self discharge.

ENGINE COOLING SYSTEM

pulsar
NS400

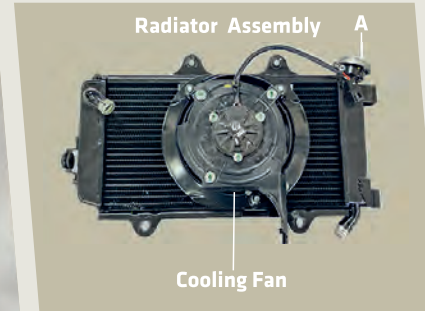
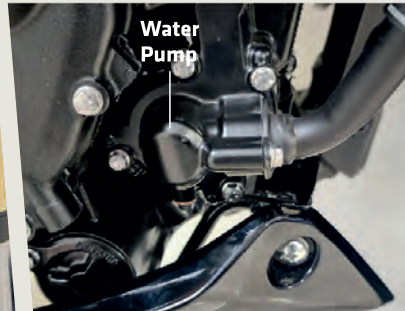
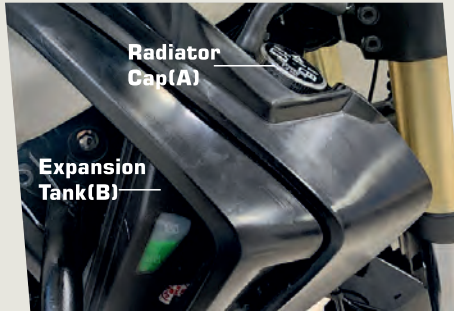

- Coolant is provided for cooling of engine.
- Water pump in the engine circulates the coolant in cooling system.
- The pressure resulting from the warning of the cooling system is regulated by a valve in radiator cap (A).
- Heat expansion causes excess coolant to flow into expansion tank (B).
- When the coolant temperature drops, this surplus coolant is sucked back into the cooling system.
- Cooling fan is provided for cooling of coolant circulated through radiator fins.

Note:

Fan will start at temp 95°C and stops at 90°C. This is normal condition & it indicates cooling system functioning well.

⚠ Warning:

During operation, the coolant gets very hot & is under pressure. In case of scalding, rinse immediately with lukewarm water. Do not remove radiator hose or other cooling system components when the engine is hot. Allow the engine & cooling system to cool down.

COOLANT



Coolant level
inspection window

⚠ Warning:

Coolant is poisonous and causes health hazard. Avoid contact between coolant & skin, eyes and clothing. If it gets into your eyes, rinse immediately with water and contact a doctor.

Wash affected skin areas immediately with soap and water. If coolant is swallowed, contact a doctor immediately change clothes that have come in contact with coolant keep coolant out of the reach of children.

Coolant Specifications:

Use antifreeze ready to use "Bajaj Koolex" coolant only.

Total coolant quantity:

1000 ml.

(750~780 ml in radiator & 220~230 ml expansion tank).

pulsar
NS400



Coolant Top up:

- Park vehicle perpendicular to the ground on level surface by using side stand.
- Check coolant level in engine cold condition only.
- Ensure coolant level is between Min & MAX mark.
- Always top up coolant through expansion tank cap (A).
- Always replace coolant with "Bajaj Koolex" coolant only.
- Use nitrile rubber hand gloves while draining & topping up coolant.
- Do not top up coolant through radiator cap.

PERIODIC MAINTENANCE INFORMATION

Pulsar
NS400

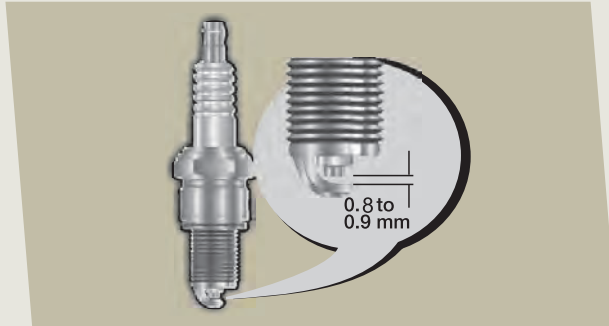

Spark Plug:

- Remove spark plugs by using plug spanner.
- Clean the spark plugs.
- Adjust the gaps if incorrect by bending outer electrode carefully.

Spark Plugs Gap: 0.8 to 0.9 mm.

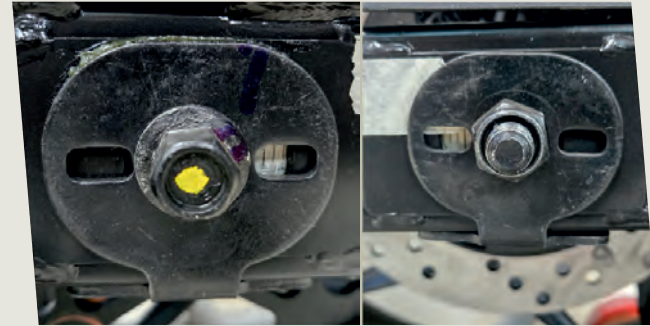

Drive Chain Slackness:

- Chain slackness will have to be adjusted whenever required.
- Std. Chain slackness 20 ~ 30 mm.
- Marking on chain adjusters should be identically positioned on both sides.

PERIODIC MAINTENANCE INFORMATION

pulsar
NS400

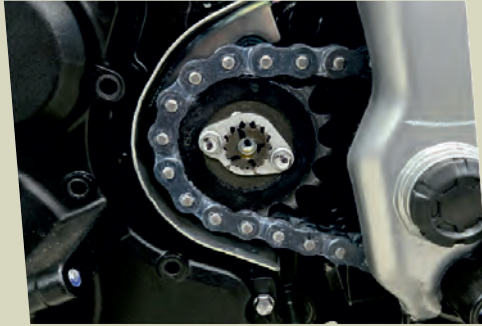

**Drive Chain
Cleaning**



**Drive Chain
Lubrication**

Drive chain must be clean & lubricate as per periodic maintenance schedule.

Drive Chain (Sealed type)

- 'O' rings must always be kept wet for best performance hence lubricate every 500 km.
- Sealed chain lubrication can easily be done by owners using Bajaj 'Chain Lube Spray Can' available with BAL dealers.

Method of sealed type Chain Lubrication:

- Park vehicle perpendicular to the ground on level surface Clean the chain by using lint free cloth (If excessive Mud / slush found approach Bajaj Service Center for proper cleaning).
- Shake the can vigorously by holding vertically upright till the noise of steel ball inside heard uniformly.
- Hold spray cat at the back of rear sprocket with extension tube nose at 5~10 cm.
- Rotate the wheel in reverse direction & spray the lube on middle portion of the chain up to full length of the chain.

BRAKE FLUID

pulsar
NS400



Front Brake Fluid Reservoir



Rear Brake Fluid Reservoir

Front & Rear Brake Fluid Level:

- Front brake fluid reservoir is located on RH side of handle bar.
- Rear brake fluid reservoir is located behind RH pillion holder bracket.
- To check the brake fluid level, park the vehicle perpendicular to the ground on level surface with handle bar in straight ahead condition.

- Always ensure that brake fluid level is above 'MIN' mark given on inspection window.
- In case of level drop, use only DOT-4 brake fluid (from sealed container) for top up & replacement.

VEHICLE CLEANING AND WASHING CARE



Regular cleaning not only enhances the appearance of your motorcycle but also plays a crucial role in maintaining its performance and extending its life by preventing rust, corrosion, and premature wear. We recommend following the guidelines below:

Washing Preparation:

- Ensure the engine and all hot components have completely cooled.
- Cover sensitive parts such as the muffler tail end, speedometer, headlamp, tail lamp, Indicators and control switches to prevent water entry and avoid damage or fogging.

Washing Instructions:

- Rinse the vehicle with clean water using a low-pressure spray to remove loose dirt and debris.
- Avoid spraying water directly on electrical, electronic components, the Oil cooler, lights, switches, or the muffler.
- Use a neutral pH bike cleaner; avoid harsh chemicals or household cleaning agents.
- Clean surfaces gently with a sponge or soft brush to prevent scratches.
- Rinse and wipe using a clean microfiber cloth, followed by thorough drying with low air pressure.
- Ensure all electrical connections are clean and moisture-free.
- Lubricate the drive chain and other moving parts after washing and drying.

Important Do's & Don'ts:

- Recommended washing pressure is up to 20 bar; maintain a 2-meter distance and avoid directing the jet at any spot for more than 10 seconds to prevent damage to electrical components like LCDs, LEDs, and other sensitive parts.
- Do not spray water into the air cleaner or throttle body, as it may cause starting issues.
- Avoid removing the seat or any other components during pressure washing to prevent water ingress.
- After washing, gently apply brakes at low speed to dry them; clean brake discs or pads if necessary.
- For matte-painted surfaces, avoid using wax or polish. Instead, clean with mild detergent and a soft cloth.



Note : Headlight lenses may temporarily fog up after washing or riding in the rain. This is normal and does not affect functionality. However, if the moisture/water accumulation is high, please visit the nearest BAL dealer for vehicle inspection.

Following these simple steps will help keep your motorcycle in excellent condition and ensure its reliable performance.



Monsoon Care Tips for Your Vehicle

Avoid riding through deep water, as it may cause water ingress into the engine and electrical components, leading to damage.

If your vehicle gets submerged or stops while riding through water, do not attempt to restart it. Take it to the nearest Bajaj workshop for inspection.

Ride cautiously on wet roads. Avoid sudden acceleration, braking, or sharp turns. Use both brakes gently and ensure your tyres have adequate tread and correct air pressure.

Keep the brakes clean and dry. Mud and slurry deposits can lead to premature brake lining wear.

After riding through mud or slurry, wash and dry your vehicle thoroughly especially the metallic parts, underbody, and wheels, to prevent rust.

Clean and lubricate the drive chain frequently during the monsoon to prevent rust and ensure smooth performance.

Warranty Exclusions

Damages due to natural calamities like floods, fire, earthquakes, lightning, or any other act of God are not covered under warranty.

Failures resulting from external conditions such as water ingress due to riding through water, or premature wear of brake pads or discs caused by prolonged exposure to slurry (Muddy water) are not covered, particularly during the rainy season.

Note:

Headlight, tail lamp, or blinker lenses may temporarily fog up after rain or washing. If excessive moisture or water accumulation persists, please visit the nearest Bajaj dealer for inspection.

FREE SERVICE GUIDELINES



Instruction to avail Free Service through Digitized Free Service Coupon

Please follow following procedure : -

- Please provide your mobile number to Dealer at the time of buying of new Bajaj Vehicle.
- In case of change in mobile number, please update to Dealer / ASD.
- When you are at Dealership / ASD workshop for availing Free Service, you will receive the 'Unique Coupon Number' (UCN) through SMS in your mobile.
- Please inform the UCN to Dealer / ASD at the time of Free Service.
(ASD-Authorised Service Dealer)

Periodic Service Criteria			
Service	Days	km	whichever occurs earlier
1st Free Service	30~45	500~750	
2nd Free Service	240	4500~5000	
3rd Free Service	360	9500~10000	
Subsequent Paid services	120 Days from last Service	Every 5000 km after previous service	

Availing all Free / paid Services, replacing mandatory periodic parts & engine oil will entitle warranty eligibility.

PERIODIC MAINTENANCE & LUBRICATION CHART



Sr. No.	Activities / Check points	Recommended frequency - Service interval & Kms							
		Servicing	1st (Free)	2nd (Free)	3rd (Free)	4th	5th	6th	7th
		KMS	500 750	4500 5000	9500 10000	14500 15000	19500 20000	24500 25000	29500 30000
1.	Servicing with water wash	✓	✓	✓	✓	✓	✓	✓	✓
2.	Engine oil (Bajaj DTSI 10000 oil)	Top-up,R	R	Top-up	R	Top-up	R	Top-up	R
3.	Engine oil Filter	R	R		R		R		R
4.	Engine oil strainer & Evacuation oil strainer	CL	CL		CL		CL		CL
5.	Air cleaner element** & air filter cover 'O' ring. Drain tube cleaning.	R					R		
6.	Throttle body rubber duct (Sleeve) for hard resulting in loose fitment.	C,R				C,R	C,R	C,R	C,R
7.	Spark plug clean & check gap	CL,A, R			CL,A		CL,A		R
8.	Valve tappet clearance	C, A					C, A		
9.	Engine breather tube for cracks.	C,R			C,R	C,R	C,R	C,R	C,R
10.	EVAP system Hoses- check for cracks	C,R		C,R	C,R	C,R	C,R	C,R	C,R
11.	Radiator fins	C,R		C,R	C,R	C,R	C,R	C,R	C,R
12.	Throttle body cleaning	CL		CL	CL	CL	CL	CL	CL

PERIODIC MAINTENANCE & LUBRICATION CHART



Recommended frequency - Service interval & Kms									Remarks
8th	9th	10th	11th	12th	13th	14th	15th	16th	
34500 35000	39500 40000	44500 45000	49500 50000	54500 55000	59500 60000	64500 65000	69500 70000	74500 75000	
✓	✓	✓	✓	✓	✓	✓	✓	✓	Ensure to prevent water entry in Petrol tank, Silencer & electrical parts. Use caustic free solution for washing.
Top-up	R	Top-up	R	Top-up	R	Top-up	R	Top-up	Use BGO 10W50 BS6. Oil level window cleaning at every 10,000 km by petrol spray & nylon brush.
	R		R		R		R		Replace oil filter in 1st service & at every 10,000 km
	CL		CL		CL		CL		Oil strainer cleaning at the time of oil change.
	R				R				Replace viscous filter at every 20,000 km No Cleaning
C,R	C,R	C,R	C,R	C,R	C,R	C,R	C,R	C,R	Replace if required
	CL,A		CL,A		R		CL,A		Replace at every 30,000 km
	C, A				C, A				Check & adjust at every 20,000 km
C,R	C,R	C,R	C,R	C,R	C,R	C,R	C,R	C,R	Replace if required
C,R	C,R	C,R	C,R	C,R	C,R	C,R	C,R	C,R	Replace if found cut / damaged
C,R	C,R	C,R	C,R	C,R	C,R	C,R	C,R	C,R	If found damaged, replace it
CL	CL	CL	CL	CL	CL	CL	CL	CL	Clean at every 5,000 km with recommended throttle body cleaning agent.

PERIODIC MAINTENANCE & LUBRICATION CHART



Sr. No.	Activities / Check points	Recommended frequency - Service interval & Kms							
		Servicing	1st (Free)	2nd (Free)	3rd (Free)	4th	5th	6th	7th
		KMS	500 750	4500 5000	9500 10000	14500 15000	19500 20000	24500 25000	29500 30000
13.	Check Coolant level in expansion tank / Hose clamp adjustment	C,A	C,A	C,A	C,A	C,A	C,A	C,A	C,A
14.	Coolant & Radiator hoses	Replacement at every 30,000 km or 3 year (whichever occurs earlier)							
15.	Silencer drain hole cleaning	CL			CL	CL	CL	CL	CL
16.	Water Pump seals	R							
17.	Wiring harness connections, routine & Conduit / PVC sleeve inspection.	C,A,T	C,A,T	C,A,T	C,A,T	C,A,T	C,A,T	C,A,T	C,A,T
18.	Battery , connections & health by load tester. +ve terminal cap fitment.	C,A,L,T	C,A,L,T	C,A,L,T	C,A,L,T	C,A,L,T	C,A,L,T	C,A,L,T	C,A,L,T
19.	Ignition switch contacts cleaning	CL,L			CL,L	CL,L	CL,L	CL,L	CL,L
20.	HT coil connections	C,T		C,T	C,T	C,T	C,T	C,T	C,T
21.	Starter motor & starter relay connections	C,T		C,T	C,T	C,T	C,T	C,T	C,T
22.	Oil pressure indicator check on console post ignition ON.	C,R	C,R	C,R	C,R	C,R	C,R	C,R	C,R
23.	Check fault code, Clear fault history, Update latest hex file if applicable	C	C	C	C	C	C	C	C
24.	Sealed Drive chain wear**- Clean, Lubricate & adjust. Replace if required	CL,L,A	CL,L,A	CL,L,A	CL,L,A	CL,L,A	CL,L,A	CL,L,A	CL,L,A

PERIODIC MAINTENANCE & LUBRICATION CHART



Recommended frequency - Service interval & Kms									Remarks
8th	9th	10th	11th	12th	13th	14th	15th	16th	
34500 35000	39500 40000	44500 45000	49500 50000	54500 55000	59500 60000	64500 65000	69500 70000	74500 75000	
C,A	C,A	C,A	C,A	C,A	C,A	C,A	C,A	C,A	Coolant top up if required Use BAJAJ Koolex coolant only.
Replacement at every 30000 Kms or 3 year (whichever occurs earlier)									
CL	CL	CL	CL	CL	CL	CL	CL	CL	
	R								Replace water pump oil seals at every 40,000 km
C,A,T	C,A,T	C,A,T	C,A,T	C,A,T	C,A,T	C,A,T	C,A,T	C,A,T	Damaged conduit / PVC sleeves protection by applying electrical tape film
C,A,L,T	C,A,L,T	C,A,L,T	C,A,L,T	C,A,L,T	C,A,L,T	C,A,L,T	C,A,L,T	C,A,L,T	Apply petroleum jelly on battery terminals. Use midtronics battery tester
CL,L	CL,L	CL,L	CL,L	CL,L	CL,L	CL,L	CL,L	CL,L	Use recommended WD40 spray
C,T	C,T	C,T	C,T	C,T	C,T	C,T	C,T	C,T	
C,T	C,T	C,T	C,T	C,T	C,T	C,T	C,T	C,T	
C,R	C,R	C,R	C,R	C,R	C,R	C,R	C,R	C,R	Icon should disappear post engine ON. After 4000 rpm, no icon should be displayed.
C	C	C	C	C	C	C	C	C	
CL,L,A	CL,L,A	CL,L,A	CL,L,A	CL,L,A	CL,L,A	CL,L,A	CL,L,A	CL,L,A	During 1st free service use OKS spray for chain cleaning without removing chain from vehicle. •During other services clean chain with Diesel+SAE 90 oil ratio of 50:50 & lubricate by SAE 90 oil,(Customer to use OKS chain lub spray at every 500 km)

PERIODIC MAINTENANCE & LUBRICATION CHART



Sr. No.	Activities / Check points	Recommended frequency - Service interval & Kms							
		Servicing	1st (Free)	2nd (Free)	3rd (Free)	4th	5th	6th	7th
		KMS	500 750	4500 5000	9500 10000	14500 15000	19500 20000	24500 25000	29500 30000
25.	Side stand pivot pin	C,L					C,L		
26.	Steering play	C,A	C,A	C,A	C,A	C,A	C,A	C,A	C,A
27.	Steering stem bearing & Cap steering bearing (Plastic)**	C,CL,L			C,CL,L		C,CL,L		C,CL,L
28.	Front fork oil & seal	C,R	C,R	C,R	C,R	C,R	C,R	C,R	R
29.	Step-pillion LH & RH (Ball & Plate)	CL,L		CL,L	CL,L	CL,L	CL,L	CL,L	CL,L
30.	Swing arm NRB for more play	L							
31.	Brake pads for wear limit.	C,R	C,R	C,R	C,R	R	C,R	C,R	R
32.	Check source of leakages if any in the brake system. Check Front & rear brake hose condition. Check Brake fluid level and top up, if needed.	C,A,R	C,A,R	C,A,R	C,A,R	C,A,R	C,A,R	C,A,R	R
33.	Rear sprocket fasteners for looseness.	C,T	C,T		C,T		C,T		C,T
34.	Rear wheel rubber shock dampers for excess play.	C,R			C,R		C,R		C,R
35.	Clutch cable free play adjustment	C,A	C,A	C,A	C,A	C,A	C,A	C,A	C,A
36.	Head light focus adjustment	C,A	C,A	C,A	C,A	C,A	C,A	C,A	C,A
37.	Check & confirm all bulbs / switches working.	C,A	C,A	C,A	C,A	C,A	C,A	C,A	C,A

PERIODIC MAINTENANCE & LUBRICATION CHART



Recommended frequency - Service interval & Kms									Remarks
8th	9th	10th	11th	12th	13th	14th	15th	16th	
34500 35000	39500 40000	44500 45000	49500 50000	54500 55000	59500 60000	64500 65000	69500 70000	74500 75000	
	C,L				C,L				Use recommended AP grease.
C,A	C,A	C,A	C,A	C,A	C,A	C,A	C,A	C,A	
	C,CL,L		C,CL,L		C,CL,L		C,CL,L		Replace if required. Use Limaplex grease for lubrication
C,R	C,R	C,R	C,R	C,R	R	C,R	C,R	C,R	Replace oil and oil seal and dust seal in pair at every 30,000 km
CL,L	CL,L	CL,L	CL,L	CL,L	CL,L	CL,L	CL,L	CL,L	Replace ball & plate, if required.
	L								Lubricate at every 40,000 km.
C,R	C,R	R	C,R	C,R	R	C,R	C,R	R	Replace at every 15,000 km
C,A,R	C,A,R	C,A,R	C,A,R	C,A,R	R	C,A,R	C,A,R	C,A,R	Check & Top up DOT 4 brake oil in every service. Replace DOT 4 brake oil & Master / Caliper seals at every 30,000 km
	C,T		C,T		C,T		C,T		Use model wise torque values.
	C,R		C,R		C,R		C,R		Replace rear wheel rubber shock damper if required
C,A	C,A	C,A	C,A	C,A	C,A	C,A	C,A	C,A	Replace cables if operation found hard.
C,A	C,A	C,A	C,A	C,A	C,A	C,A	C,A	C,A	
C,A	C,A	C,A	C,A	C,A	C,A	C,A	C,A	C,A	Contact type switches if found sticky then use recommended WD40 spray

PERIODIC MAINTENANCE & LUBRICATION CHART



Sr. No.	Activities / Check points	Recommended frequency - Service interval & Kms							
		Servicing	1st (Free)	2nd (Free)	3rd (Free)	4th	5th	6th	7th
		KMS	500 750	4500 5000	9500 10000	14500 15000	19500 20000	24500 25000	29500 30000
38.	General lubrication – Clutch lever	L	L	L	L	L	L	L	L
39.	Tyre air pressure.	C,A	C,A	C,A	C,A	C,A	C,A	C,A	C,A
40.	Mirror position & joint firmness.	C,A	C,A	C,A	C,A	C,A	C,A	C,A	C,A
41.	Mobile USB port	C,R	C,R	C,R	C,R	C,R	C,R	C,R	C,R
42.	All fasteners tightness, few are, Front & rear axle, Swing arm axle, Rider foot rest, Pillion stay	C,T	C,T	C,T	C,T	C,T	C,T	C,T	C,T

*It is strongly recommended to use only Bajaj genuine oil.

****More frequent cleaning may be required while driving in dusty environment.**

C : Check, A : Adjust, CL : Clean, R : Replace, T : Tighten, L : Lubricate

Note : Periodic parts, Oil, Coolant, Filters, All types of greases, Cleaning agents, Cables, Wear & tear parts, Rubber 'O' rings / oil seals / pipes, Gaskets to be replaced as per Periodic Maintenance and Lubrication Chart are mandatory and the same are chargeable to customer.

PERIODIC MAINTENANCE & LUBRICATION CHART



Recommended frequency - Service interval & Kms									Remarks
8th	9th	10th	11th	12th	13th	14th	15th	16th	
34500 35000	39500 40000	44500 45000	49500 50000	54500 55000	59500 60000	64500 65000	69500 70000	74500 75000	
L	L	L	L	L	L	L	L	L	Use recommended AP grease.
C,A	C,A	C,A	C,A	C,A	C,A	C,A	C,A	C,A	Ensure model wise tyre air pressure.
C,A	C,A	C,A	C,A	C,A	C,A	C,A	C,A	C,A	
C,R	C,R	C,R	C,R	C,R	C,R	C,R	C,R	C,R	Charging OK to be checked at Engine start condition using LED USB light
C,T	C,T	C,T	C,T	C,T	C,T	C,T	C,T	C,T	Use model wise torque values.

NON USE MAINTENANCE



Non-use maintenance is necessary if a vehicle remains off road for a longer duration (more than 15 days**). The correct and careful non-use maintenance carried out before storing the vehicle will prevent the vehicle from rusting and from such other non-operational damages like fire hazards.

- Clean the entire vehicle thoroughly.
- Empty the fuel from the fuel tank (if fuel is left in for a longer time, the fuel will break and gummy substance could clog the fuel system & fuel pipe).
- Remove spark plug & put several drops of engine oil into the cylinder. Kick engine over slowly a few times to coat cylinder wall with oil & install back spark plug.
- Set the vehicle on a box or a stand so that both wheels are raised off the ground.
- Spray oil on all unpainted metal surfaces to prevent rusting. Avoid getting oil on rubber parts or brake liners.
- Cover entire vehicle neatly. Make sure that storage area is well ventilated & free from any source of flames or spark.
- Fill 10% excess air pressure in both wheels.
- Do not apply oil on front brake disc, to prevent rusting. If the front brake disc rusts during storage, do not attempt to clean it with soap water. The rust will go off automatically during first few application of brake.

** For Battery :

- a. Remove battery and keep it on wooden plank, in properly ventilated area.
 - b. Before taking the vehicle for use.
- Get the battery recharged from the Authorised Service Dealer / Battery Dealer.
 - Apply petroleum jelly on battery terminals.

Preparation for regular use after storage :

- Follow daily safety checklist mentioned on page no 29.

WARRANTY : SCOPE & LIMIT



Bajaj Auto Limited provides the following warranty in respect of the **"Pulsar NS 400 BS VI"** motorcycle manufactured by us.

Every possible care and precaution has been taken to ensure quality in respect of the material & workmanship in the vehicles manufactured by us. Bajaj Auto Limited will repair or replace at their Authorised Workshops, free of charge, part or parts there of as may be found, on examination, to have manufacturing defect within a period of 5 Years or 75,000 km., whichever is earlier from the date of sale subject to fulfillment of conditions stipulated in part A, B & C given here under

Note : Warranty is applicable for only first owner of vehicle.

Part A:

Warranty claims in respect of such items like shock absorbers, speedometers etc. though claimed through us, are subject to acceptance of the respective manufacturers. In all such cases the decision of the respective manufacturer will be final and binding.

Proprietary parts like tyres, tubes and battery are warranted by their respective manufacturers and should be claimed on them directly by the customer. Bajaj Auto Limited shall not be Liable to replace them though their dealer, however BAL Dealers will provide full assistance in

referring such claims with respective manufacturer.

Bajaj Auto Limited undertake no liability in the matter of consequential loss or damage caused due to the failure of the parts. Delay, if any, at the repairing workshop in carrying out repair to vehicle shall not be a ground for extending the warranty period, nor shall it give any right to the customer for claiming any compensation for damages.

Bajaj Auto Limited reserves the right either to repair or replace the defective parts.

Where a defective part can be replaced by part/s of alternative brand/s, which are normally used by Bajaj Auto Limited in the course of manufacture, Bajaj Auto Limited reserves the right to carry out the replacement by a part or parts of any such alternative brand/s.

This warranty and any claim arising there, is subject to Pune jurisdiction only.

Part B:

No claim for exchange or repair can be considered unless the customer :

- a. Ensures that immediately upon detection of the defect, he approaches any nearest BAL Authorised Vehicle Dealers & Recommended BAL Authorised Service Dealers with the concerned vehicle and enables him to remove and despatch the part / parts attributing to the manufacturing defect to the Company.

WARRANTY : SCOPE & LIMIT



b. Produces the Owner's Manual, in original, to enable that dealer to verify the details.

It must be expressly understood that claims forwarded directly to us by the owner / customer will not be entertained at all and such defective part/parts thus forwarded by them will lie at our factory at their own risk, and this warranty shall not be enforceable.

To avail benefits of warranty, following are mandatory

1. Availing of Initial 3 Free Services without lapse.
2. Availing paid services at subsequent 5,000 km. or 120 days from last service whichever is earlier without any lapse.
3. Availing of all services at the BAL Authorised Dealers & Recommended BAL Authorised Service Dealers.
4. Usage of only recommended engine oil **"Bajaj 10000 10W50"** at specified frequency for drain interval of 10,000 km. & engine oil level top-up at 5,000 km.
5. Replacing mandatory periodic parts such as air filter, oil filter etc. as per periodic maintenance schedule.

Part C :

Further this warranty is NOT applicable to :

1. Normal maintenance operations like brake & clutch adjustments, cleaning of fuel system, engine tune-up or such other adjustments.
2. Parts subjected to normal wear & tear like Clutch Plates, Brake Shoes, Chain, Sprockets, Fork Oil Seal, Spark Plug, Control Cables, Brake Pads.
3. Replacement of bulbs & rubber components like grommets, 'O' rings, bellows as well as filters, packings, gaskets, fasteners etc.
4. Painted parts. Only blistering or peeling off of paint film are covered under warranty. Any defect arising out due to external damages or due to usage of protective covers /additional protective coatings adverse atmospheric conditions etc. are not allowed like under warranty.
5. All consumables like Engine oil, Fork oil, Brake Oil, Grease etc. are chargeable to customer.
6. Any defect arising due to above consumables not changed as per scheduled or if used other than the recommended one.
7. Never drive your bike through flooded roads or a flooded patch, as damages to the engine parts due to water entry is not covered under warranty.

WARRANTY : SCOPE & LIMIT



8. All chrome plated parts are prone to rust or corrosion in coastal area or in acidic environment or due to neglected cleaning etc. However chrome film peeling is covered under warranty in general atmospheric conditions. Blue/ Yellow colouration of silencer near exhaust port is permissible and hence not covered under warranty.
 9. Oxidation of unpainted/painted crankcase, cylinder block, cylinder head etc. in acidic environment or in a coastal area.
 10. Parts of the vehicle that have been subjected to misuse, accident, negligent treatment OR which have been used in conjunction with parts & an equipment not manufactured or recommended for use by Bajaj Auto Limited, if found is the sole judgement of Bajaj Auto Limited, such use prematurely affects the performance and reliability of the vehicle.
 11. Parts of the vehicle that have been altered and modified or replaced in unauthorized manner like use of wider tyres, loud silencers etc and which in the sole judgement of the Bajaj Auto Limited affects its performance and reliability.
 12. **Vehicles which are not being serviced at recommended BAL authorized dealers as per the service schedule described or which have not been operated or maintained in accordance with the instructions maintained in the Owner's Manual.**
 13. Vehicles used for any competition or race and/or for attempting to set up any kind of record.
 14. Any failure arising due to use of adulterated or bad quality fuel.
Parts affected due to bad fuel quality are not covered Under warranty.
 15. If additional electrical accessories such as - Remote, Bigger horn, Musical brake light etc. fitted on vehicle.
 16. If the vehicle has been used for commercial purpose like Taxi or any other means of commercial transportation.
- Bajaj Auto Limited reserves the right to make any changes in design or to add any improvements on the vehicle at any time without incurring any obligation to install the same on a vehicle previously supplied and sold. Also, the conditions of this warranty are subject to alteration without any notice.
- This warranty is the entire written warranty given by Bajaj Auto Limited for "**Pulsar NS 400 BS VI**" motorcycle' and no other dealer or its or his agent or employee is authorised to extend or enlarge this warranty.

BATTERY WARRANTY CARD



MAKE OF BATTERY :

MFG. CODE OF BATTERY :

SR.NO.:

TYPE OF BATTERY :

DATE OF SALE :

NAME OF OWNER AND ADDRESS :

TYPE OF VEHICLE : REG. NO.:

FRAME NO.: ENGINE NO.:

SERVICE RECORD

Sr. No.	Date	Age Mths.	Voltage	Remarks	Dealer's Stamp & Signature	* Code
1						
2						
3						
4						
5						
6						

*** Code For Remarks:**

- AE** : Electrical system needs attention.
- IR** : Insufficient running of vehicle.
- CB** : Cover broken.
- BC** : Broken Container.
- PM** : Poor maintenance.
- BA** : Battery abused.

Note : Customer should insist that "Service Record" must be filled by respective authorised battery dealer as proof of specified maintenance for easy settlement of claim, if any.

TO BE FILLED IN BY BATTERY DEALERS / DISTRIBUTORS IN CASE OF CLAIM



Name of Dealer & Code : _____

Date of claim : _____ Battery Type : _____

Serial No. : _____ Date of Fitment : _____

Failure Mode (Please tick as applicable)

- **Loose connection**
- **Internal Short**
- **Plate Shedding**
- **Wrong Assembly**
- **Wrong Application**
- **Overcharge / Undercharge**
- **Reverse Charge**
- **Does not Hold Charge**
- **Left Lying Idle**
- **Terminal Corroded**

Claim Accepted

Claim Rejected

Details of Repair, if any _____

Note:

Please contact nearest respective authorised battery dealer for details immediately after purchase of vehicle.

USE ONLY BAJAJ GENUINE PARTS

pulsar
NS400

4T
Premium
Engine Oil



LONGEST ENGINE OIL CHANGE INTERVAL OF 10,000* KM

Synthetic Engine Oil Ultimate Performance



Reduced Friction



Clean Engine Parts



Smooth Clutch Control



*Top up recommended at 5,000 km.



Top up bottle



Always Use Bajaj Genuine Parts & High Performance Engine Oils

We are committed to provide the best of sales & service experience, however should you require any additional assistance, please call our Call centre on the number given below.



: 7219821111

[Call charges are as applicable](#)

Call centre timings :- Monday to Sunday
(09 : 00 am - 08 : 00 pm)



Please download customer care app from '**Google play store**' and '**Apple store**' and book the vehicles for servicing and more on your phone.

E-mail : customerservice@bajajauto.co.in

Web Site : www.bajajauto.com

CIN : L65993PN2007PLC130076